

■ Type List for Large and For Audio Aluminum Electrolytic Capacitors

Category	Series	Page	Applications	Feature							Category Temp. Range °C		Rated Voltage Range V.DC		Rated capacitance Range μF	Color of sleeve	JIS Configuration	Note			
				Thin and small Size	Reliability at 105°C					Low impedance	For Audio	Anti-cleaning solvent	Reflow Soldering Resistance	Max.					Min.	Max.	Min.
					1000hrs	2000hrs	3000hrs	5000hrs	10000hrs												
Large Capacitance Type	LA5	86	PCB Terminal, Snap-In Type	•								+85	-40	400	10	56 to 82000	Black	—			
	LH7	—										+85	-40	200	16	47 to 15000	Black	692			
	L3J	—	105°C, Standard		•							+105	-40	200	10	150 to 22000	Black	692			
	LAG	88	High-Reliability, High Ripple	•	•							+105	-25	400	160	39 to 1800	Black	692			
	LAH	90	High-Reliability, Ultra-Miniaturized	•	•							+105	-25	450	16	56 to 47000	Black	692			
	LAT	93	Super Miniaturization, High Ripple	•	•							+105	-25	400	160	82 to 2700	Black	692			
	LAV	—	105°C, Compatible with VDE		•							+105	-25	250	—	82 to 1000	Black	692			
	LUH	95	105°C, Durable against Over Voltage		•							+105	-25	400	200	68 to 1500	Black	692			
	LAX	96	105°C, Ultra-Longevity	•			•					+105	-25	400	160	56 to 1800	Black				
For Audio	RVO	98	Chip Type (PURECAP)	•					•	•	+85	-40	50	6.3	0.1 to 1000	Silver Brown	32				
	RVW	99	Chip Type 105°C (PURECAP)	•	•				•	•	+105	-40	50	6.3	0.1 to 1000	Silver Brown	32				
	RFS	100	High Grade (SILMIC I)						•		+85	-55	100	6.3	0.47 to 3300		04				
	ROS	101	High Grade (SILMIC)						•		+85	-40	100	16	2.2 to 4700		04				
	ROA	102	High Grade (Cerafine)						•		+85	-40	100	6.3	0.47 to 6800		04				
	ROB	103	Miniaturized Standard (TONEREX)						•		+85	-40	100	6.3	0.47 to 10000		04				
	R20	104	Miniaturized Standard	•					•		+85	-40	100	6.3	0.47 to 15000		04				
	R2A	105	7mm L	•					•		+85	-40	50	4	0.1 to 330		04				
	R3A	106	5mm L	•					•		+85	-40	50	4	0.1 to 220		04				
	RFO	107	Standard (PURECAP)	•					•		+85	-40	100	6.3	0.47 to 15000		04				
	RA2	108	Standard	•					•		+85	-40	100	6.3	0.47 to 15000		04				
	RA3	109	Miniaturized Standard	•					•		+85	-40	100	6.3	0.1 to 22000		04				
	RBD	110	Miniaturized Bipolar	•					•		+85	-40	100	6.3	0.1 to 4700		04				
	LAO	111	For Audio (TONEREX)						•		+85	-40	50	16	680 to 10000		692				

* Be sure to "Cautions for Using Aluminum Electrolytic Capacitors", before using these products.

Old series were deleted from catalog, the productions were discontinued.

For new designation, please use the substitute series.

It is greatly appreciated that you would understand and accept the proposal stated in above.

Category	Series	JIS Configuration	Features	Substitute series	Page
Surface mounting type	RT	32	Higher capacitance, Vibration resistance	RTJ, RTH	55, 56
Standard type	RE2	04	Miniaturized standard	RE3	65
	RBP	04	Bipolarity standard	R2B	67
High reliability type	RSL	04	105°C Long Life	RK	83
	RKA	04	130°C Long Life	Consult us	-
Large capacitance type	LP5	692	PCB terminal, Snap-in type	LA5	86
	L3J	692	105°C Standard	LAH	90
	LPG	692	High reliability, High ripple	LAG	88
	LPH	692	High reliability, Ultra-miniaturized	LAH	90
	LPT	692	Super-miniaturized, High ripple	LAT	93
	LUV	692	105°C Compatible with VDE	LAV	—
	LPX	692	105°C Ultra-Long Life	LAX	96
For Audio	ROS (ø22 to 30)	04	High grade(SILMIC)	Consult us	—

Standard Capacitors

GREEN CAP

Anti-cleaning solvent 250V Max.

• Guarantees 2000 hours at 85°C.

RJ4

High temperature

RE3



Marking color : White print on a blue sleeve

Specifications

Item	Performance																																															
Category temperature range (°C)	-40 to +85																																															
Tolerance at rated capacitance (%)	±20 (20°C,120Hz)																																															
Leakage current (µA)	<table border="1"> <tr> <td>Rated voltage (V)</td> <td>6.3 to 100</td> <td>160 to 450</td> </tr> <tr> <td>Leakage current (µA)</td> <td>Less than 0.03CV or 4 whichever is larger(after 1 minute) Less than 0.01CV or 3 whichever is larger(after 2 minutes)</td> <td>CV≤1000: Less than 0.1CV+40(after 1 minute) CV>1000: Less than 0.04CV+100(after 1 minute)</td> </tr> </table>	Rated voltage (V)	6.3 to 100	160 to 450	Leakage current (µA)	Less than 0.03CV or 4 whichever is larger(after 1 minute) Less than 0.01CV or 3 whichever is larger(after 2 minutes)	CV≤1000: Less than 0.1CV+40(after 1 minute) CV>1000: Less than 0.04CV+100(after 1 minute)																																									
	Rated voltage (V)	6.3 to 100	160 to 450																																													
Leakage current (µA)	Less than 0.03CV or 4 whichever is larger(after 1 minute) Less than 0.01CV or 3 whichever is larger(after 2 minutes)	CV≤1000: Less than 0.1CV+40(after 1 minute) CV>1000: Less than 0.04CV+100(after 1 minute)																																														
C: Rated capacitance(µF) V: Rated voltage(V) (20°C)																																																
Tangent of loss angle (tanδ)	<table border="1"> <tr> <td>Rated voltage (V)</td> <td>6.3</td><td>10</td><td>16</td><td>25</td><td>35</td><td>50</td><td>63</td><td>100</td><td>160</td><td>200</td><td>250</td><td>315</td><td>350</td><td>400</td><td>450</td> </tr> <tr> <td>tanδ (max.)</td> <td>0.28</td><td>0.24</td><td>0.20</td><td>0.16</td><td>0.14</td><td>0.12</td><td>0.10</td><td>0.08</td><td>0.20</td><td>0.20</td><td>0.20</td><td>0.24</td><td>0.24</td><td>0.24</td><td>0.24</td> </tr> </table>	Rated voltage (V)	6.3	10	16	25	35	50	63	100	160	200	250	315	350	400	450	tanδ (max.)	0.28	0.24	0.20	0.16	0.14	0.12	0.10	0.08	0.20	0.20	0.20	0.24	0.24	0.24	0.24															
	Rated voltage (V)	6.3	10	16	25	35	50	63	100	160	200	250	315	350	400	450																																
tanδ (max.)	0.28	0.24	0.20	0.16	0.14	0.12	0.10	0.08	0.20	0.20	0.20	0.24	0.24	0.24	0.24																																	
0.02 is added to every 1000µF increase over 1000µF. (20°C,120Hz)																																																
Characteristics at high and low temperature	<table border="1"> <tr> <td>Rated voltage (V)</td> <td>6.3</td><td>10</td><td>16</td><td>25</td><td>35</td><td>50</td><td>63</td><td>100</td><td>160</td><td>200</td><td>250</td><td>315</td><td>350</td><td>400</td><td>450</td> </tr> <tr> <td rowspan="2">Impedance ratio (max.)</td> <td>Z-25°C / Z+20°C</td> <td>5</td><td>4</td><td>3</td><td>2</td><td>2</td><td>2</td><td>2</td><td>4</td><td>4</td><td>4</td><td>4</td><td>4</td><td>4</td><td>4</td> </tr> <tr> <td>Z-40°C / Z+20°C</td> <td>12</td><td>10</td><td>8</td><td>5</td><td>4</td><td>3</td><td>3</td><td>3</td><td>15</td><td>15</td><td>15</td><td>10</td><td>10</td><td>10</td> </tr> </table>	Rated voltage (V)	6.3	10	16	25	35	50	63	100	160	200	250	315	350	400	450	Impedance ratio (max.)	Z-25°C / Z+20°C	5	4	3	2	2	2	2	4	4	4	4	4	4	4	Z-40°C / Z+20°C	12	10	8	5	4	3	3	3	15	15	15	10	10	10
	Rated voltage (V)	6.3	10	16	25	35	50	63	100	160	200	250	315	350	400	450																																
Impedance ratio (max.)	Z-25°C / Z+20°C	5	4	3	2	2	2	2	4	4	4	4	4	4	4																																	
	Z-40°C / Z+20°C	12	10	8	5	4	3	3	3	15	15	15	10	10	10																																	
(120Hz)																																																
Endurance (85°C) (Applied ripple current)	Test time	2000 hours																																														
	Leakage current	The initial specified value or less																																														
	Percentage of capacitance change	Within ±20% of initial value																																														
	Tangent of the loss angle	200% or less of the initial specified value																																														
Shelf life (85°C)	Test time : 1000 hours; other items are the same as those for the endurance. Voltage application treatment																																															
Applicable standards	JIS C5101-1, -4 1998 (IEC 60384-1 1992, -4 1985)																																															

Miniature Aluminum Electrolytic Capacitors

Outline Drawing

Unit: mm

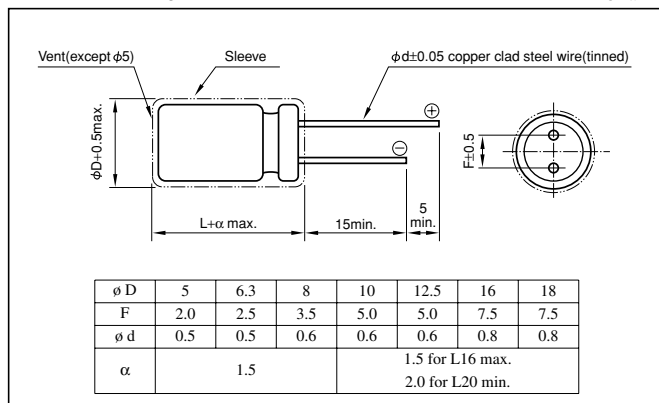

Coefficient of Frequency for Rated Ripple Current

Rated voltage(V)	Frequency(Hz) CV(µF×WV)	50 - 60	120	1k	10k	100k
		6.3 to 16	All CV value	0.8	1	1.1
25 to 35	≤1000	0.8	1	1.5	1.7	1.7
	1000<	0.8	1	1.2	1.3	1.3
50 to 100	≤1000	0.8	1	1.6	1.9	1.9
	1000<	0.8	1	1.2	1.3	1.3
160 to 450	All CV value	0.8	1	1.3	1.5	1.6

Part numbering system (example: 16V100µF)

RE3	—	16	V	102	M	H4	#
Series code		Rated voltage symbol		Rated capacitance symbol	Capacitance tolerance symbol	Casing symbol	

Casing symbol

Size φ DxL(mm)	Casing Symbol	Size φ DxL(mm)	Casing Symbol
5x11	E3	12.5x25	I 6
6.3x11	F3	16x25	J 6
8x11.5	G3	16x31.5	J 7
10x12.5	H3	16x35.5	J 8
10x16	H4	18x35.5	K8
10x20	H5	18x40	K9
12.5x20	I 5		

• The standard ratings are described on the next page.

NOTE
Design, Specifications are subject to change without notice.
Ask factory for technical specifications before purchase and/or use.

Standard Ratings

Rated capacitance (μF)	Item	6.3			10			16			25			35			50			63			100										
		Case	ESR	Rated ripple current	Case	ESR	Rated ripple current	Case	ESR	Rated ripple current	Case	ESR	Rated ripple current	Case	ESR	Rated ripple current	Case	ESR	Rated ripple current	Case	ESR	Rated ripple current	Case	ESR	Rated ripple current								
		φD x L (mm)	Ω	mArms	φD x L (mm)	Ω	mArms	φD x L (mm)	Ω	mArms	φD x L (mm)	Ω	mArms	φD x L (mm)	Ω	mArms	φD x L (mm)	Ω	mArms	φD x L (mm)	Ω	mArms	φD x L (mm)	Ω	mArms								
0.1	—	—	—	—	—	—	—	—	—	—	—	—	—	—	—	5x11	1990	3	—	—	—	5x11	1330	2.1									
0.22	—	—	—	—	—	—	—	—	—	—	—	—	—	—	—	5x11	905	6	—	—	—	5x11	603	4.7									
0.33	—	—	—	—	—	—	—	—	—	—	—	—	—	—	—	5x11	603	9	—	—	—	5x11	402	7									
0.47	—	—	—	—	—	—	—	—	—	—	—	—	—	—	—	5x11	423	13	—	—	—	5x11	282	10									
1	—	—	—	—	—	—	—	—	—	—	—	—	—	—	—	5x11	199	21	—	—	—	5x11	133	21									
2.2	—	—	—	—	—	—	—	—	—	—	—	—	—	—	—	5x11	90.5	31	—	—	—	5x11	60.3	30									
3.3	—	—	—	—	—	—	—	—	—	—	—	—	—	—	—	5x11	60.3	38	—	—	—	5x11	40.2	40									
4.7	—	—	—	—	—	—	—	—	—	—	—	—	—	—	—	5x11	56.5	38	5x11	49.4	40	5x11	42.3	45	5x11	35.3	45	5x11	28.2	45			
10	—	—	—	—	—	—	—	—	—	—	—	—	—	—	—	5x11	33.2	50	5x11	26.5	55	5x11	23.2	59	5x11	19.9	66	5x11	16.6	66	6.3x11	13.3	75
22	—	—	—	—	—	—	—	—	—	—	—	—	—	—	—	5x11	15.1	75	5x11	12.1	82	5x11	10.6	87	5x11	9.05	98	5x11	7.54	100	6.3x11	6.03	130
33	—	—	—	—	—	—	—	—	—	—	—	—	—	—	—	5x11	10.1	92	5x11	8.04	100	5x11	7.04	107	5x11	6.03	126	6.3x11	5.03	140	8x11.5	4.02	180
47	—	—	—	5x11	8.47	99	5x11	7.06	110	5x11	5.65	118	5x11	4.94	130	6.3x11	4.23	155	6.3x11	3.53	170	10x12.5	2.82	230									
100	—	—	—	5x11	3.78	146	5x11	3.32	160	6.3x11	2.65	199	6.3x11	2.32	214	8x11.5	1.99	260	10x12.5	1.66	300	10x20	1.33	370									
220	5x11	2.11	200	6.3x11	1.81	240	6.3x11	1.51	264	8x11.5	1.21	349	10x12.5	1.06	443	10x12.5	0.905	443	10x16	7.54	470	12.5x20	0.603	620									
330	6.3x11	1.41	270	6.3x11	1.21	290	8x11.5	1.01	383	10x12.5	0.804	510	10x12.5	0.704	542	10x16	0.603	595	10x20	0.503	710	12.5x25	0.402	760									
470	6.3x11	0.988	322	8x11.5	0.847	417	8x11.5	0.706	457	10x12.5	0.565	545	10x16	0.494	664	12.5x20	0.423	887	12.5x20	0.353	900	16x25	0.282	1000									
1000	8x11.5	0.464	546	10x12.5	0.398	650	10x16	0.332	791	10x20	0.265	996	12.5x20	0.232	1210	12.5x25	0.199	1400	16x25	0.166	1300	18x40	0.133	1380									
2200	10x20	0.226	1010	10x20	0.196	1080	12.5x20	0.166	1350	12.5x25	0.136	1660	16x25	0.121	1950	16x35.5	0.106	2340	—	—	—	—	—	—									
3300	10x20	0.161	1230	12.5x20	0.141	1430	12.5x25	0.121	1690	16x25	0.101	2030	16x35.5	0.09	2510	18x35.5	0.08	2810	—	—	—	—	—	—									
4700	12.5x20	0.12	1710	12.5x25	0.106	1780	16x25	0.092	2100	16x31.5	0.078	2650	18x35.5	0.071	2990	—	—	—	—	—	—	—	—	—									
6800	12.5x25	0.093	1930	16x25	0.083	2200	16x35.5	0.073	2580	18x35.5	0.063	3290	—	—	—	—	—	—	—	—	—	—	—	—									
10000	16x25	0.076	2450	16x35.5	0.07	2700	18x35.5	0.063	3100	—	—	—	—	—	—	—	—	—	—	—	—	—	—	—									
15000	16x35.5	0.062	2860	18x35.5	0.058	3100	—	—	—	—	—	—	—	—	—	—	—	—	—	—	—	—	—	—									
22000	18x40	0.053	3340	—	—	—	—	—	—	—	—	—	—	—	—	—	—	—	—	—	—	—	—	—									

Miniature Aluminum Electrolytic Capacitors

Rated capacitance (μF)	Item	160			200			250			315			350			400			450			
		Case	ESR	Rated ripple current	Case	ESR	Rated ripple current	Case	ESR	Rated ripple current	Case	ESR	Rated ripple current	Case	ESR	Rated ripple current	Case	ESR	Rated ripple current	Case	ESR	Rated ripple current	
		φD x L (mm)	Ω	mArms	φD x L (mm)	Ω	mArms	φD x L (mm)	Ω	mArms	φD x L (mm)	Ω	mArms	φD x L (mm)	Ω	mArms	φD x L (mm)	Ω	mArms	φD x L (mm)	Ω	mArms	
0.47	6.3x11	706	15	6.3x11	706	15	6.3x11	706	15	6.3x11	847	15	6.3x11	847	15	6.3x11	847	15	8x11.5	847	18		
1	6.3x11	332	22	6.3x11	332	22	6.3x11	332	22	6.3x11	398	22	6.3x11	398	22	6.3x11	398	22	8x11.5	398	25		
2.2	6.3x11	151	32	6.3x11	151	32	6.3x11	151	32	8x11.5	181	38	8x11.5	181	38	8x11.5	181	38	10x12.5	181	43		
3.3	6.3x11	101	40	6.3x11	101	40	8x11.5	101	48	10x12.5	121	53	10x12.5	121	53	10x12.5	121	54	10x16	121	59		
4.7	6.3x11	70.6	48	8x11.5	70.6	56	8x11.5	70.6	56	10x12.5	84.7	65	10x12.5	84.7	65	10x16	84.7	71	10x20	84.7	76		
10	8x11.5	33.2	81	10x12.5	33.2	94	10x16	33.2	101	10x20	39.8	115	10x20	39.8	115	12.5x20	39.8	123	12.5x20	39.8	123		
22	10x16	15.1	151	10x20	15.1	170	12.5x20	15.1	182	12.5x20	18.1	182	12.5x25	18.1	197	12.5x25	18.1	197	16x25	18.1	226		
33	10x20	10.1	202	12.5x20	10.1	223	12.5x25	10.1	243	16x25	12.1	277	16x25	12.1	277	16x25	12.1	277	16x31.5	12.1	304		
47	12.5x20	7.06	266	12.5x25	7.06	265	12.5x25	7.06	295	16x25	8.47	330	16x25	8.47	330	16x31.5	8.47	361	16x35.5	8.47	380		
100	12.5x25	3.32	422	16x25	3.32	483	16x31.5	3.32	528	18x31.5	3.98	567	18x31.5	3.98	567	—	—	—	—	—	—	—	
220	16x31.5	1.51	783	18x35.5	1.51	882	—	—	—	—	—	—	—	—	—	—	—	—	—	—	—	—	
330	18x35.5	1.01	1080	—	—	—	—	—	—	—	—	—	—	—	—	—	—	—	—	—	—	—	—

(Note) ESR : 20°C, 120Hz ; Rated ripple current : 85°C, 120Hz