

# LUXEON 4014

Compact footprint delivering high-efficacy and just the right amount of light



## Introduction

The LUXEON® 4014 low-power product is the first of its kind from Philips Lumileds. It's a compact 4.0 x 1.4 x 0.7 mm package that delivers the quality of light needed for indoor lighting applications. The LUXEON 4014 offers an ideal solution when uniformity and a smooth lighting appearance are critical in luminaire designs.

### Features

- Unique phosphor technology
- Rectangular QFN package design
- Superior heat dissipation
  - Flexible lumen and efficacy platform
  - ANSI color bin
  - Efficacy up to 150 lm/W @ 30 mA

### Benefits

- Enables high efficacy
- Increases uniformity
- Enables cost effective thermal design
- For added value and performance roadmap

### Key Applications

- Indoor area lighting
  - Wall grazer
  - Under cabinet
  - Cove
  - Integrated lay-in
  - Retrofit lamps
  - Refrigerator lighting

# Table of Contents

General Information . . . . .	2
Product Nomenclature . . . . .	2
Average Lumen Maintenance Characteristics . . . . .	2
Environmental Compliance . . . . .	2
Product Performance and Characterization Guide. . . . .	3
Electrical Characteristics . . . . .	3
Absolute Maximum Ratings . . . . .	4
JEDEC Moisture Sensitivity . . . . .	4
Reflow Soldering Characteristics . . . . .	5
Material Information & Mechanical Dimensions . . . . .	6
Characteristic Curves . . . . .	7
Typical Forward Current . . . . .	8
Light Output Characteristics . . . . .	9
Typical Radiation Patterns . . . . .	10
Emitter Pocket Tape Packaging . . . . .	11
Emitter Reel Packaging . . . . .	12
Product Binning and Labeling . . . . .	13
Color Bin Structure . . . . .	14

# General Information

## Product Nomenclature

LUXEON 4014 is tested and binned at  $T_j = 25^\circ\text{C}$  and 30 mA DC.

The part number designation is explained as follows:

M X Z A – B C D D – 0 0 E E

Where:

- A — designates minimum CRI (value 8 for 80, 9 for 90)
- B — designates radiation pattern (value P for Lambertian)
- C — designates color (W for White)
- D D — designates nominal CCT (27 for 2700K, 30 for 3000K, 35 for 3500K, 40 for 4000K and 50 for 5000K)
- EEEE — designates additional part numbers

Therefore 4000K, 80 CRI LUXEON 4014 product will be:

M X Z 8 – P W 4 0 – 0 0 0 0

## Average Lumen Maintenance Characteristics

Lumen maintenance for solid-state lighting devices (LEDs) is typically defined in terms of the percentage of initial light output remaining after a specified period of time. Philips Lumileds projects that LUXEON 4014 MXZ8-PW40-00 products will deliver, on average, 70% lumen maintenance (L70) at >30,000 hours of operation at a forward current of up to 30 mA. *This projection and detailed operating condition will be further validated and disclosed.* Observation of design limits included in this data sheet is required in order to achieve this projected lumen maintenance.

## Environmental Compliance

Philips Lumileds is committed to providing environmentally friendly products to the solid-state lighting market. LUXEON 4014 is compliant to the European Union directives on the restriction of hazardous substances in electronic equipment, namely the RoHS and REACH directives. Philips Lumileds will not intentionally add the following restricted material to the LUXEON 4014: lead, mercury, cadmium, hexavalent chromium, polybrominated biphenyls (PBB) or polybrominated diphenyl ethers (PBDE).

# Product Performance and Characterization Guide

## Typical Product Characteristics at 30 mA and 60 mA

**Table 1. Performance Characteristics at  $T_j = 25^\circ\text{C}$ ,  $I_f$**

Nominal CCT	Part Number	Minimum CRI	Luminous Flux @ 30 mA, 25°C		Luminous Flux @ 60 mA, 25°C		$V_f$ at 30 mA
			Minimum (lm)	Typical (lm)	Minimum (lm)	Typical (lm)	Typical
2700	MXZ8-PW27	80	8.5	10.5	15	18	2.9
3000	MXZ8-PW30	80	8.5	11	15	20	2.9
3500	MXZ8-PW35	80	9	11	16	20	2.9
4000	MXZ8-PW40	80	10	12	18	22	2.9
5000	MXZ8-PW50	80	10	12	18	22	2.9
5700	MXZ8-PW57	80	9.5	11.5	17	20	2.9
6500	MXZ8-PW65	80	9.5	11.5	17	20	2.9

**Notes for Table 1:**

1. Philips Lumileds maintains a tolerance of  $\pm 7.5\%$  on luminous flux,  $\pm 2$  on CRI.
2. Production parts are binned at 30 mA, 25°C.
3. Performance at 60 mA, 25°C is for reference only.

## Electrical Characteristics

### Electrical Characteristics of Low-Power LEDs

Solder Pad Temperature = 25°C, Test Current = 30 mA

**Table 2.**

Part Numbers	Forward Voltage $V_f$ [1] (V)			Typ. Temperature Coefficient of Forward Voltage [2] ( $\text{mV}/^\circ\text{C}$ ) $\Delta V_f / \Delta T_j$	Typical Thermal Resistance Junction to Solder Pad ( $^\circ\text{C}/\text{W}$ ) $R\theta_{j-c}$
	Minimum	Typical	Maximum		
MXZx-PWXX	2.7	2.9	3.2	-1.6	45

**Notes for Table 2:**

1. Philips Lumileds maintains a tolerance of  $\pm 0.10\text{V}$  on forward voltage measurements.
2. Measured between  $T_j = 25^\circ\text{C}$  and  $T_j = 110^\circ\text{C}$ .

## Absolute Maximum Ratings

**Table 3. Operating Condition and Ratings**

Parameter	Maximum Performance
DC Forward Current <sup>[1]</sup>	90 mA
Peak Pulsed Forward Current <sup>[2]</sup>	100 mA
Soldering Temperature	260°C
Allowable Reflow Cycles	3
ESD Sensitivity	< 2000V Human Body Model (HBM) Class 2 JEDEC JS-001-2012 400V Machine Model (MM) Class C JESD22-A115C
Storage Temperature	-40°C - 85°C
LED Junction Temperature	125°C
Operating Case Temperature	85°C
Reverse Voltage (Vr) <sup>[3][4]</sup>	-5V

**Notes for Table 3:**

1. Ripple current with a frequency of 50-150 Hz is allowed, as long as the average of the current waveform is below 80 mA, and the maximum of the current waveform is lower than 100 mA.
2. At 10% duty cycle and pulse width 10mS.
3. LUXEON low-power LEDs are not designed to be driven in reverse bias.
4. At maximum reverse current of 10  $\mu$ A.

## JEDEC Moisture Sensitivity

**Table 4.**

Level	Floor Life		Soak Requirements	
			Standard	
	Time	Conditions	Time	Conditions
2	1 year	$\leq 30^{\circ}\text{C} / 60\% \text{RH}$	168 Hrs. + 5 / -0 Hrs.	$\leq 85^{\circ}\text{C} / 60\% \text{RH}$

# Reflow Soldering Characteristics

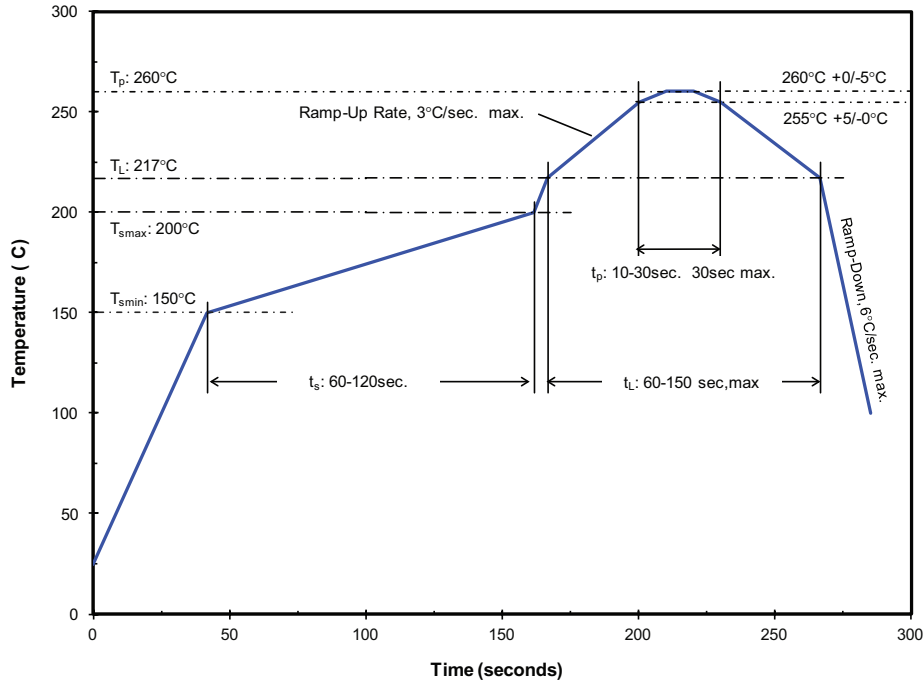

Temperature Profile for Table 5.

Table 5. Reflow Profile in Accordance with J-Std-020D.

Profile Feature	Lead Free Assembly
Preheat/Soak :	
Temperature Min ( $T_{smin}$ )	150°C
Temperature Max ( $T_{smax}$ )	200°C
Maximum Time ( $t_s$ ) from $T_{smin}$ to $T_{smax}$	120 seconds
Ramp-up Rate ( $T_L$ to $T_p$ )	3°C / second
Liquidous Temperature ( $T_L$ )	217°C
Maximum Time ( $t_L$ ) Maintained above $T_L$	150 seconds
Maximum Peak Package Body Temperature ( $T_p$ )	260°C
Time ( $t_p$ ) within 5°C of the specified temperature ( $T_c$ )	10-30 seconds
Maximum Ramp-Down Rate ( $T_p$ to $T_L$ )	6°C / second
Maximum Time 25°C to Peak Temperature	8 minutes

Note for Table 5:

- All temperatures refer to the application Printed Circuit Board (PCB), measured on the surface adjacent to the package body.

# Material Information & Mechanical Dimensions

## MXZx-PWxx

**Table 6. Material Information**

Material/Component	Specification
Lead Frame Base:	Copper Alloy
Reflector Plating:	Ni/Ag
Electrode Plating:	Ni/Ag
Package Body:	High Temperature Thermal Plastic
Encapsulant:	Silicone Resin, with Phosphor
LED Chip:	InGaN

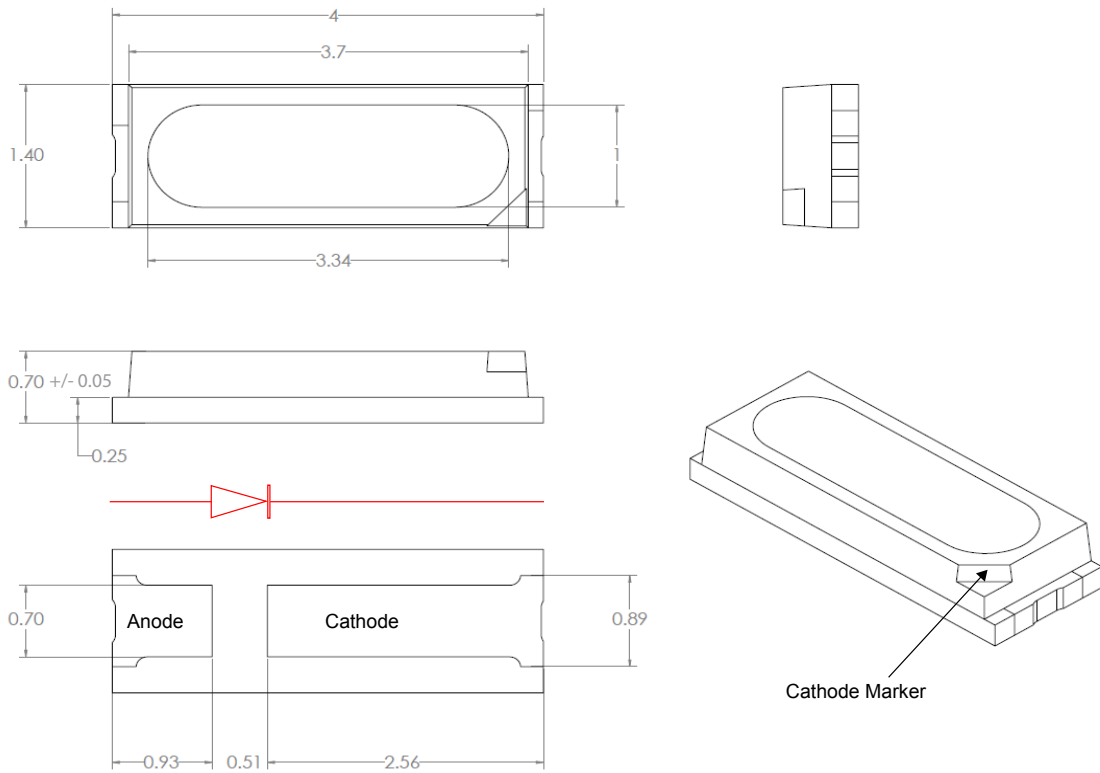

**Figure 1. Package outline dimensions.**

**Notes for Figure 1:**

1. All dimensions are in millimeters.
2. General tolerance +/- 0.10.

# Characteristic Curves

## Relative Spectral Distribution vs. Wavelength

Junction Temperature at 25°C; Test Current = 30 mA

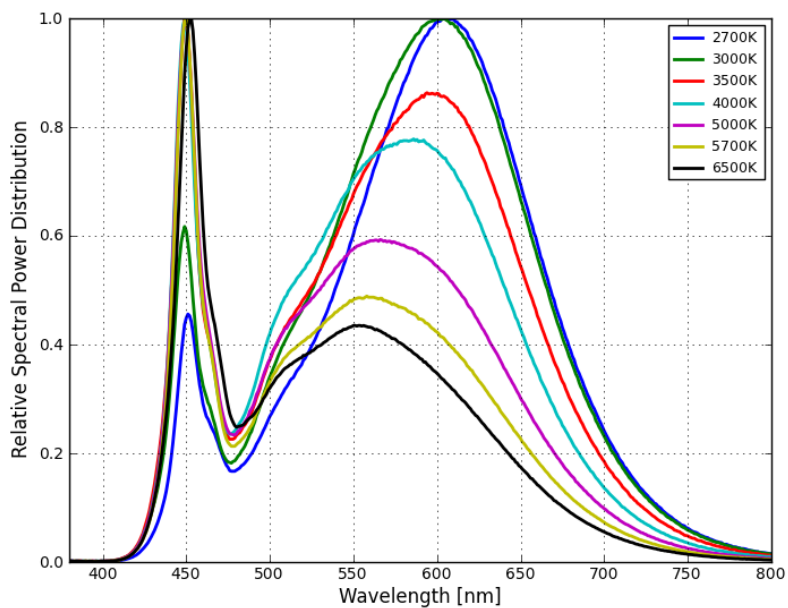

Figure 2. Emission color spectrum for MXZx-PWXX.

## Relative Light Output Characteristics over Temperature

Test Current = 30 mA

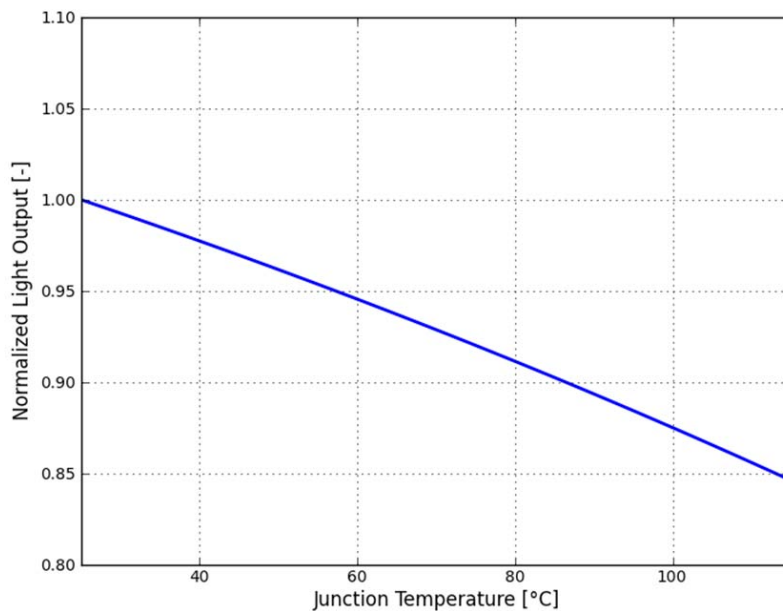

Figure 3. Relative light output vs. junction temperature for MXZx-PWXX.



# Typical Forward Current

Junction Temperature at 25°C

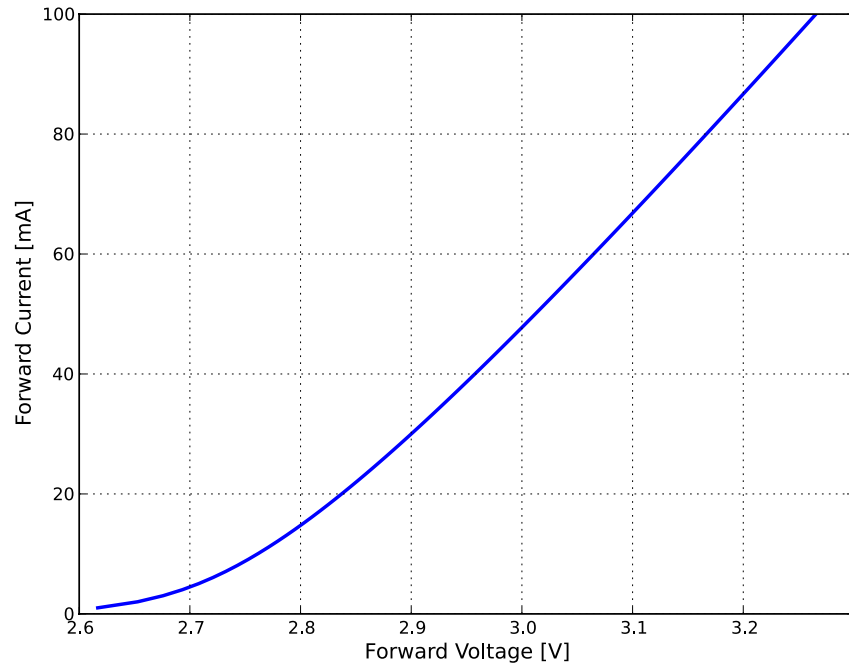

Figure 4. Forward current vs. forward voltage for MXZx-PWXX.

# Light Output Characteristics

## Relative Light Output Characteristics over Forward Current Junction Temperature at 25°C

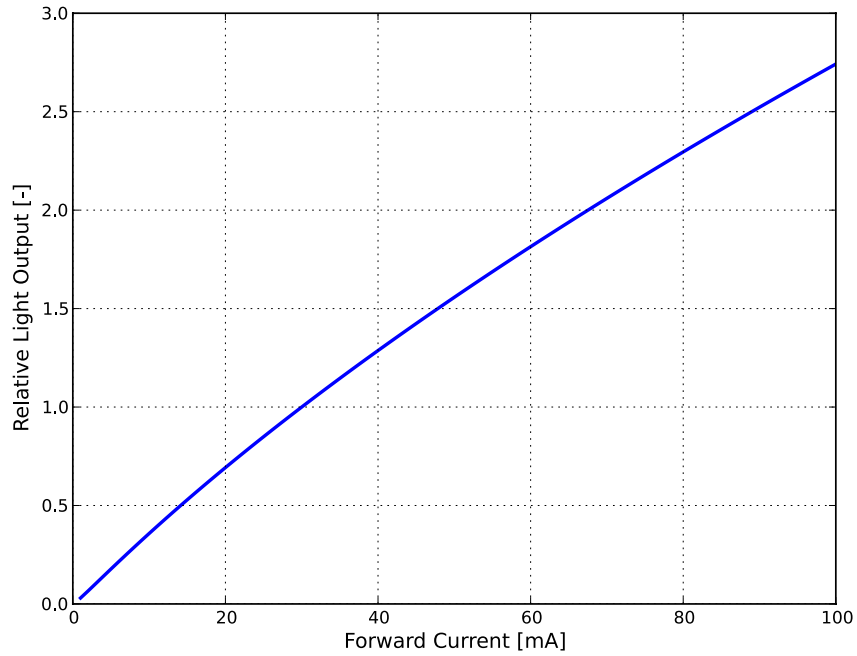

Figure 5. Light output vs. forward current for MXZx-PWXX.

## Typical Relative Efficiency vs. Forward Current Junction Temperature at 25°C

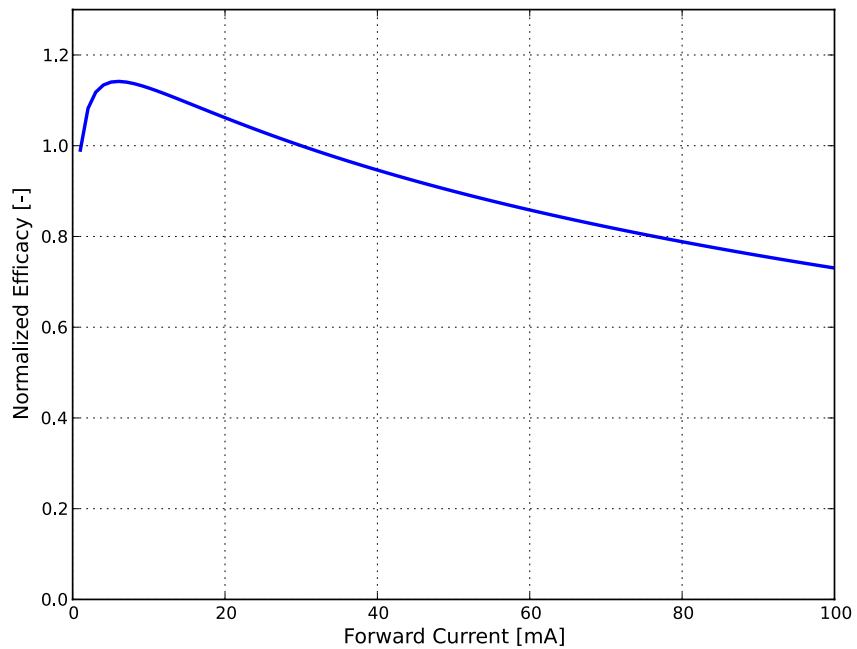

Figure 6. Typical relative efficiency vs. forward current for MXZx-PWXX.

# Typical Radiation Patterns

## Junction Temperature at 25°C

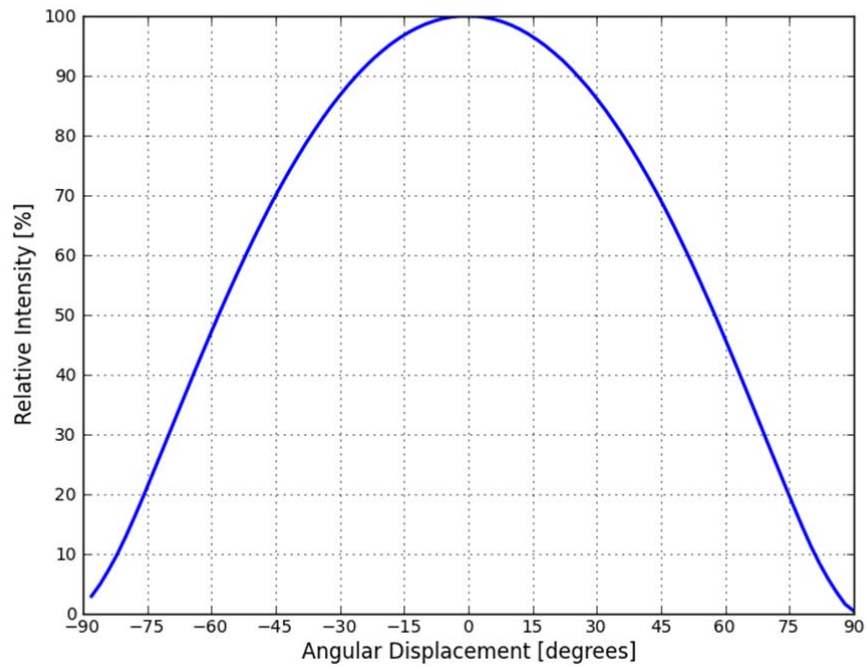

Figure 7. Radiation pattern for MXZx-PWXX.

## Polar Radiation Pattern, Junction Temperature at 25°C

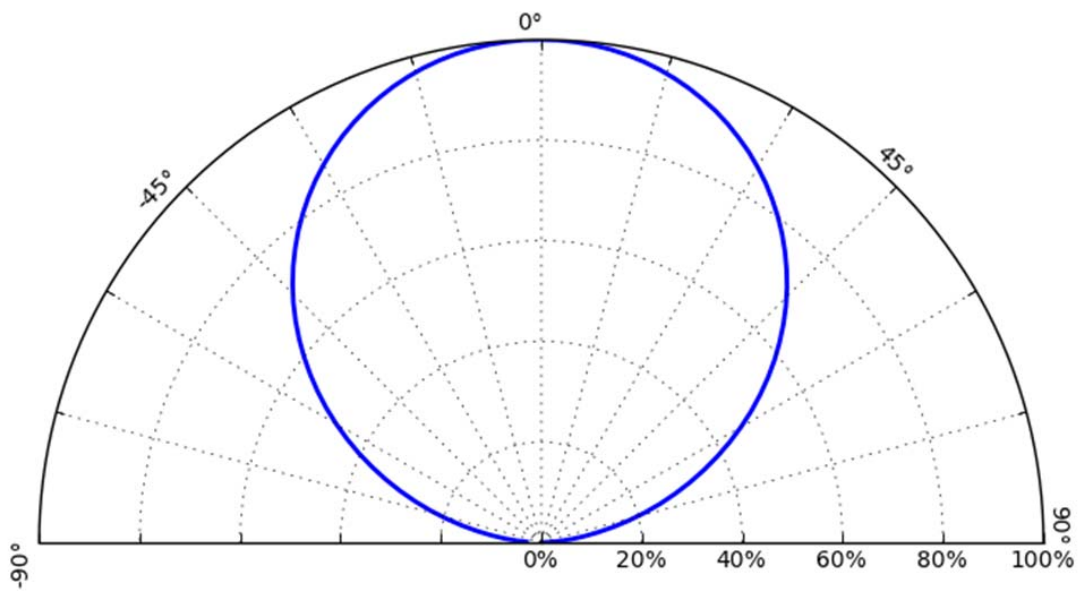
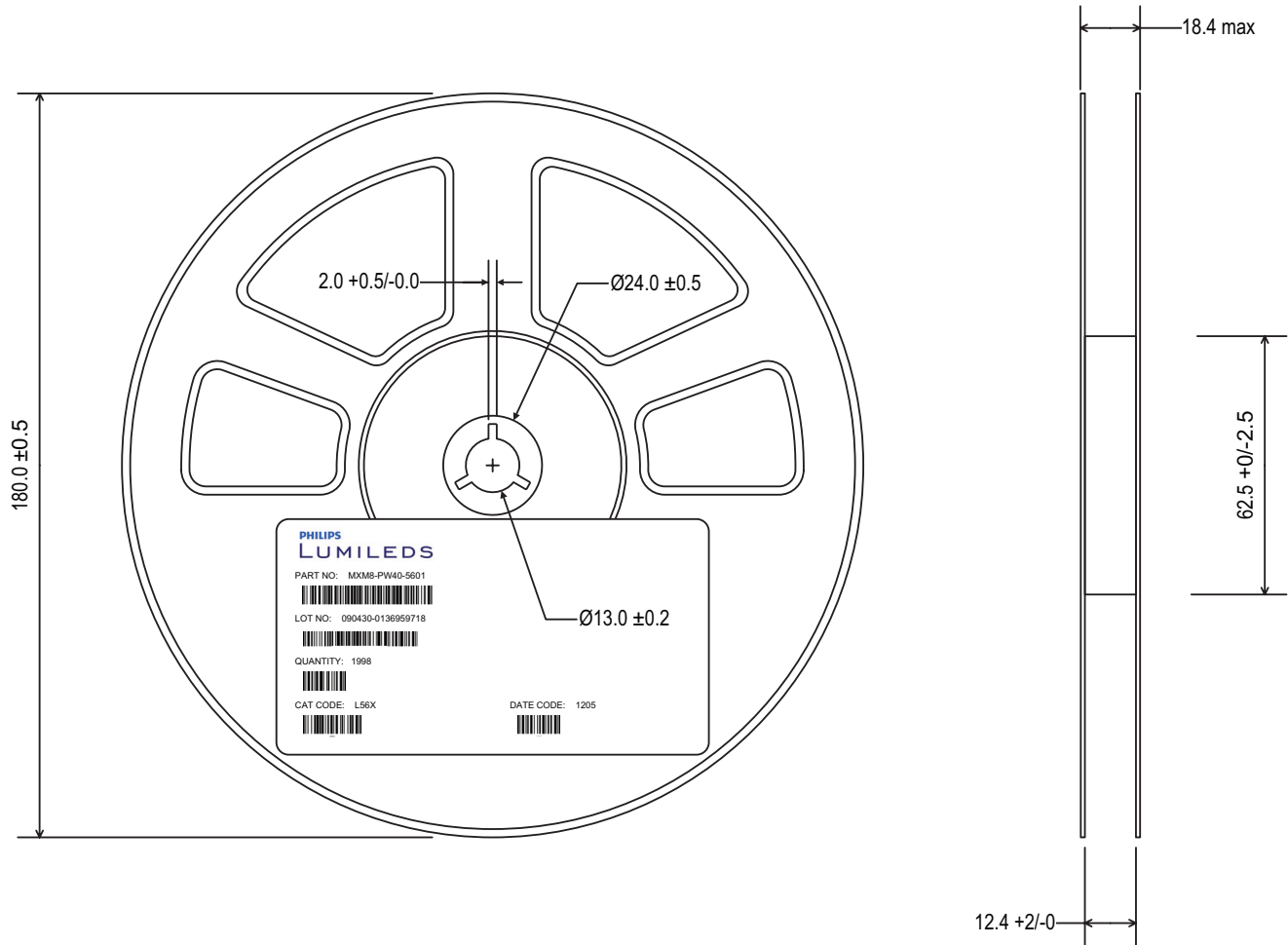

Figure 8. Radiation pattern in polar for MXZx-PWXX.



# Emitter Reel Packaging



**Figure 10. Emitter reel packaging.**

**Notes for Figure 10:**

1. All dimensions are in millimeters.
2. Empty component pockets sealed with top cover tape.
3. 7 inch reel-3000 pieces per reel.
4. Minimum packing quantity is 1000 pieces.
5. The maximum number of consecutive missing LEDs is two.
6. In accordance with EIA-481-I-B specification.

# Product Binning and Labeling

## Purpose of Product Binning

In the manufacturing of LED products, there is a distribution of performance around the typical values given in the technical data sheets. For this reason, Philips Lumileds bins the LED components for luminous flux, color and forward voltage ( $V_f$ ).

## Decoding Product Bin Labeling

LUXEON 4014 emitters are labeled using a four digit alphanumeric code (CAT code) depicting the bin values for emitters packaged on a single reel. All emitters packaged within a reel are of the same 3-variable bin combination. Using these codes, it is possible to determine optimum mixing and matching of products for consistency in a given application.

Reels of 2700K, 3000K, 3500K, 4000K, 5000K, 6500K emitters are labeled with a four digit alphanumeric CAT code following the format below.

ABCD

A = Flux bin (L etc.)

B and C = Color bin (For example 51, 52, 53, 54, 55, 56)

D =  $V_f$  bin

## Luminous Flux and Forward Voltage Bins

Tables 7 and 8 list the standard photometric luminous flux bins for LUXEON 4014 emitters (tested and binned at 30 mA). Although several bins are outlined, product availability in a particular bin varies by production run and by product performance. Not all bins are available in all colors.

**Table 7. Flux Bins**

Bin Code	Minimum Photometric Flux (lm)	Maximum Photometric Flux (lm)
A	8.5	10.0
B	10.0	11.5
C	11.5	13.0
D	13.0	15.0
E	15.0	18.0

Tested and binned at 25°C,  $I_f=30$  mA. Tester tolerance:  $\pm 7.5\%$ .

**Table 8.  $V_f$  Bins**

Bin Code	Minimum Forward Voltage (V)	Maximum Forward Voltage (V)
S	2.7	2.8
T	2.8	2.9
V	2.9	3.0
W	3.0	3.1
X	3.1	3.2

Tested and binned at 25°C,  $I_f=30$  mA. Tester tolerance:  $\pm 0.10V$ .

# Color Bin Structure

## MXZ8-PW27 Color Bin Structure

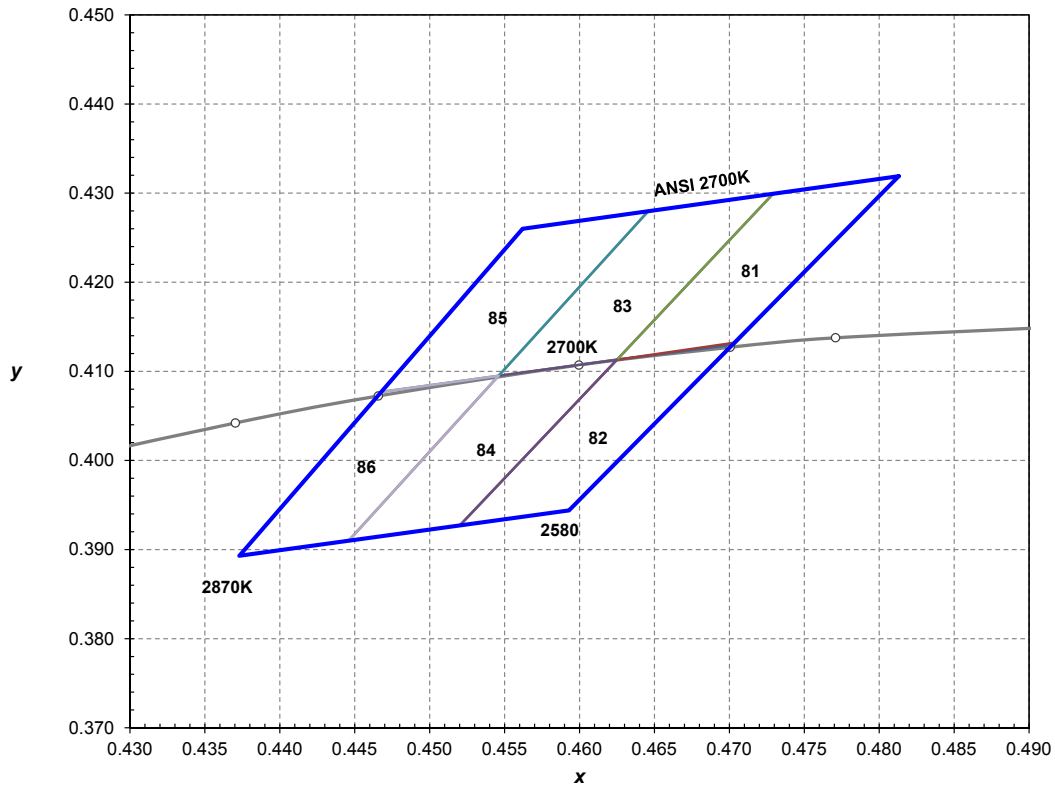

Figure 11. ANSI 2700K 1/6th color bin structure, forwards current = 30 mA, thermal pad temperature = 25°C.

LUXEON Mid-Power Emitters are tested and binned by x,y coordinates.

Table 9.

LUXEON Mid-Power ANSI 1/6 Color Bin Coordinates for MXZ8-PW27-0000 Emitter					
Bin Code	x	y	Bin Code	x	y
81	0.4625	0.4113	84	0.4446	0.3910
	0.4729	0.4299		0.4546	0.4095
	0.4813	0.4319		0.4625	0.4113
	0.4703	0.4130		0.4520	0.3927
82	0.4520	0.3927	85	0.4468	0.4077
	0.4625	0.4113		0.4562	0.4260
	0.4703	0.4132		0.4646	0.4280
	0.4593	0.3944		0.4546	0.4095
83	0.4546	0.4095	86	0.4373	0.3893
	0.4646	0.4280		0.4468	0.4077
	0.4729	0.4299		0.4546	0.4095
	0.4625	0.4113		0.4446	0.3910

**Notes for Table 9:**

I. Tested and binned at 25°C, I<sub>f</sub>=30 mA. Tester tolerance: ±0.01 in x and y coordinates.

# Color Bin Structure

## MXZ8-PW30 Color Bin Structure

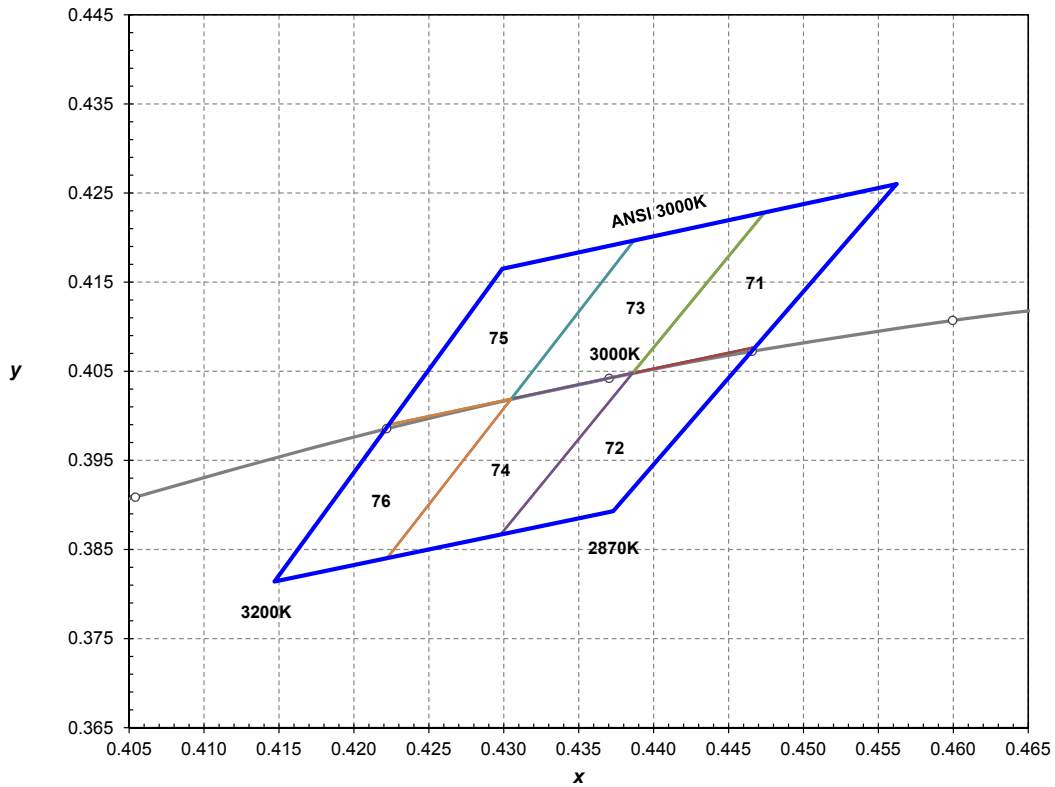

Figure 12. ANSI 3000K 1/6th color bin structure, forwards current = 30 mA, thermal pad temperature = 25°C.

LUXEON Mid-Power Emitters are tested and binned by x,y coordinates.

Table 10.

LUXEON Mid-Power ANSI 1/6 Color Bin Coordinates for MXZ8-PW30-0000 Emitter					
Bin Code	x	y	Bin Code	x	y
71	0.4386	0.4048	74	0.4222	0.3840
	0.4474	0.4228		0.4305	0.4019
	0.4562	0.4260		0.4386	0.4048
	0.4468	0.4077		0.4298	0.3867
72	0.4298	0.3867	75	0.4223	0.3990
	0.4386	0.4048		0.4299	0.4165
	0.4468	0.4077		0.4387	0.4197
	0.4373	0.3893		0.4305	0.4019
73	0.4305	0.4019	76	0.4147	0.3814
	0.4387	0.4197		0.4223	0.3990
	0.4474	0.4228		0.4305	0.4019
	0.4386	0.4048		0.4222	0.3840

**Notes for Table 10:**

I. Tested and binned at 25°C, I<sub>f</sub>=30 mA. Tester tolerance: ±0.01 in x and y coordinates.



# Color Bin Structure

## MXZ8-PW35 Color Bin Structure

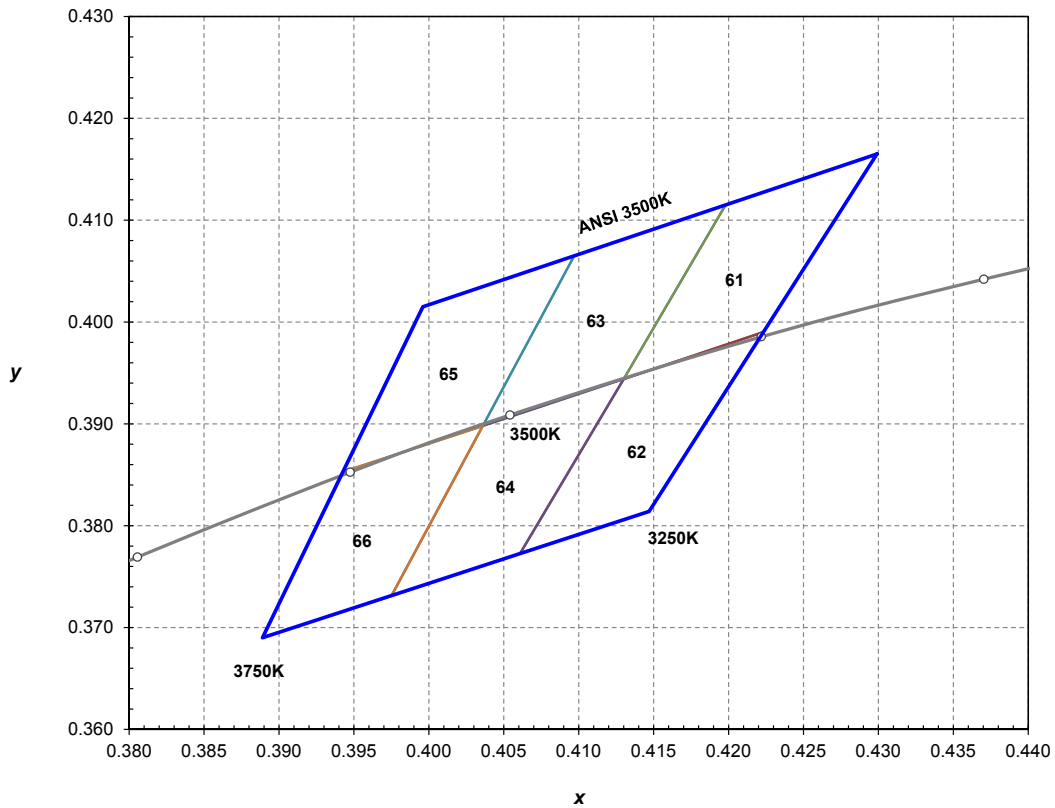

Figure 13. ANSI 3500K 1/6th color bin structure, forwards current = 30 mA, thermal pad temperature = 25°C.

LUXEON Mid-Power Emitters are tested and binned by x,y coordinates.

Table II.

LUXEON Mid-Power ANSI 1/6 Color Bin Coordinates for MXZ8-PW35-0000 Emitter					
Bin Code	x	y	Bin Code	x	y
61	0.4130	0.3944	64	0.3975	0.3731
	0.4198	0.4115		0.4036	0.3898
	0.4299	0.4165		0.4130	0.3944
	0.4223	0.3990		0.4061	0.3773
62	0.4061	0.3773	65	0.3943	0.3853
	0.4130	0.3944		0.3996	0.4015
	0.4223	0.3990		0.4097	0.4065
	0.4147	0.3814		0.4036	0.3898
63	0.4036	0.3898	66	0.3889	0.3690
	0.4097	0.4065		0.3943	0.3853
	0.4198	0.4115		0.4036	0.3898
	0.4130	0.3944		0.3975	0.3731

**Notes for Table II:**

I. Tested and binned at 25°C, I<sub>f</sub>=30 mA. Tester tolerance: ±0.01 in x and y coordinates.

# Color Bin Structure

## MXZ8-PW40 Color Bin Structure

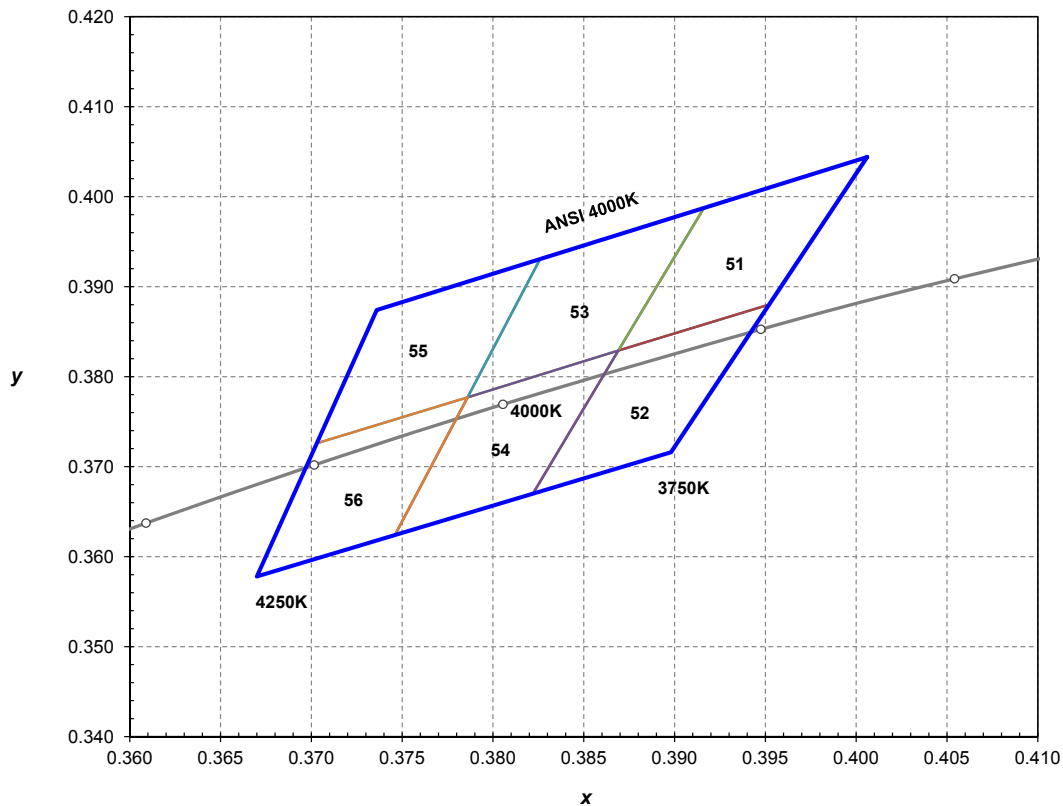

Figure 14. ANSI 4000K 1/6th color bin structure, forwards current = 30 mA, thermal pad temperature = 25°C.

LUXEON Mid-Power Emitters are tested and binned by x,y coordinates.

Table 12.

LUXEON Mid-Power ANSI 1/6 Color Bin Coordinates for MXZ8-PW40-0000 Emitter					
Bin Code	x	y	Bin Code	x	y
51	0.3869	0.3829	54	0.3746	0.3624
	0.3916	0.3987		0.3786	0.3777
	0.4006	0.4044		0.3869	0.3829
	0.3952	0.3880		0.3822	0.3670
52	0.3822	0.3670	55	0.3703	0.3726
	0.3869	0.3829		0.3736	0.3874
	0.3952	0.3880		0.3826	0.3931
	0.3898	0.3716		0.3786	0.3777
53	0.3786	0.3777	56	0.3670	0.3578
	0.3826	0.3931		0.3703	0.3726
	0.3916	0.3987		0.3786	0.3777
	0.3869	0.3829		0.3746	0.3624

**Notes for Table 12:**

I. Tested and binned at 25°C, I<sub>f</sub>=30 mA. Tester tolerance: ±0.01 in x and y coordinates.

# Color Bin Structure

## MXZ8-PW50 Color Bin Structure

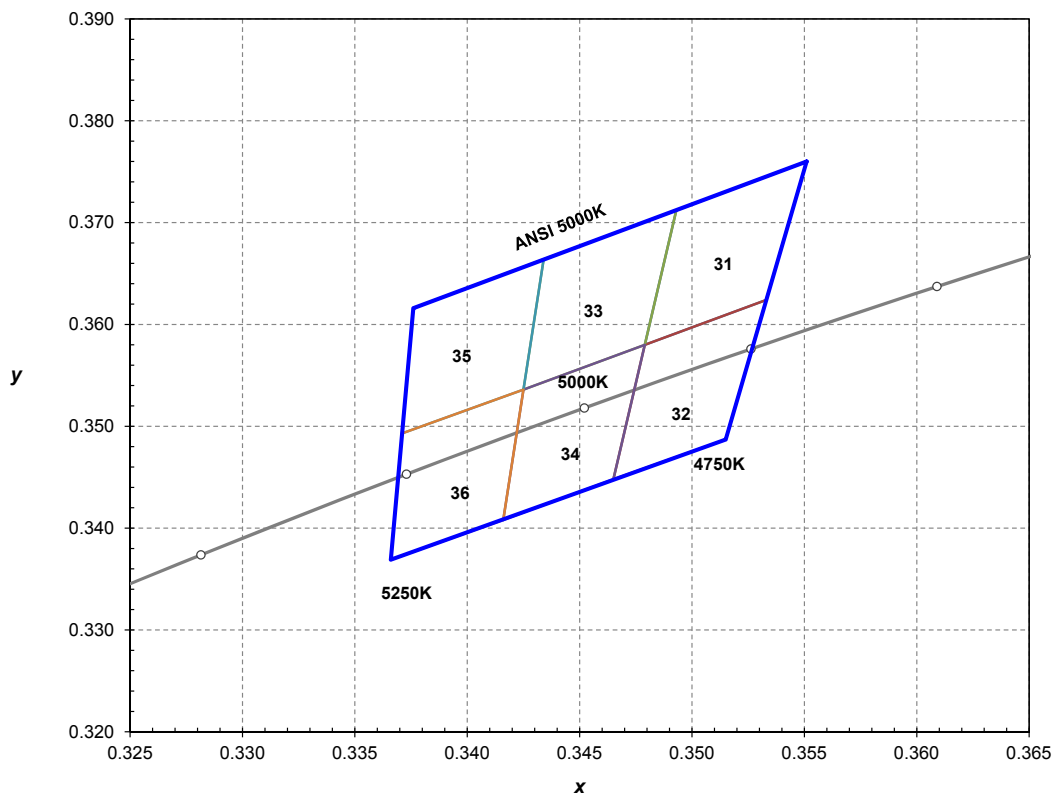

Figure 15. ANSI 5000K 1/6th color bin structure, forwards current = 30 mA, thermal pad temperature = 25°C.

LUXEON Mid-Power Emitters are tested and binned by x,y coordinates.

Table 13.

LUXEON Mid-Power ANSI 1/6 Color Bin Coordinates for MXZ8-PW50-0000 Emitter					
Bin Code	x	y	Bin Code	x	y
31	0.3479	0.3580	34	0.3416	0.3408
	0.3493	0.3712		0.3425	0.3536
	0.3551	0.3760		0.3479	0.3580
	0.3533	0.3624		0.3465	0.3448
32	0.3465	0.3448	35	0.3371	0.3493
	0.3479	0.3580		0.3376	0.3616
	0.3533	0.3624		0.3434	0.3664
	0.3515	0.3487		0.3425	0.3536
33	0.3425	0.3536	36	0.3366	0.3369
	0.3434	0.3664		0.3371	0.3493
	0.3493	0.3712		0.3425	0.3536
	0.3479	0.3580		0.3416	0.3408

**Notes for Table 13:**

I. Tested and binned at 25°C, I<sub>f</sub>=30 mA. Tester tolerance: ±0.01 in x and y coordinates.

# Color Bin Structure

## MXZ8-PW57 Color Bin Structure

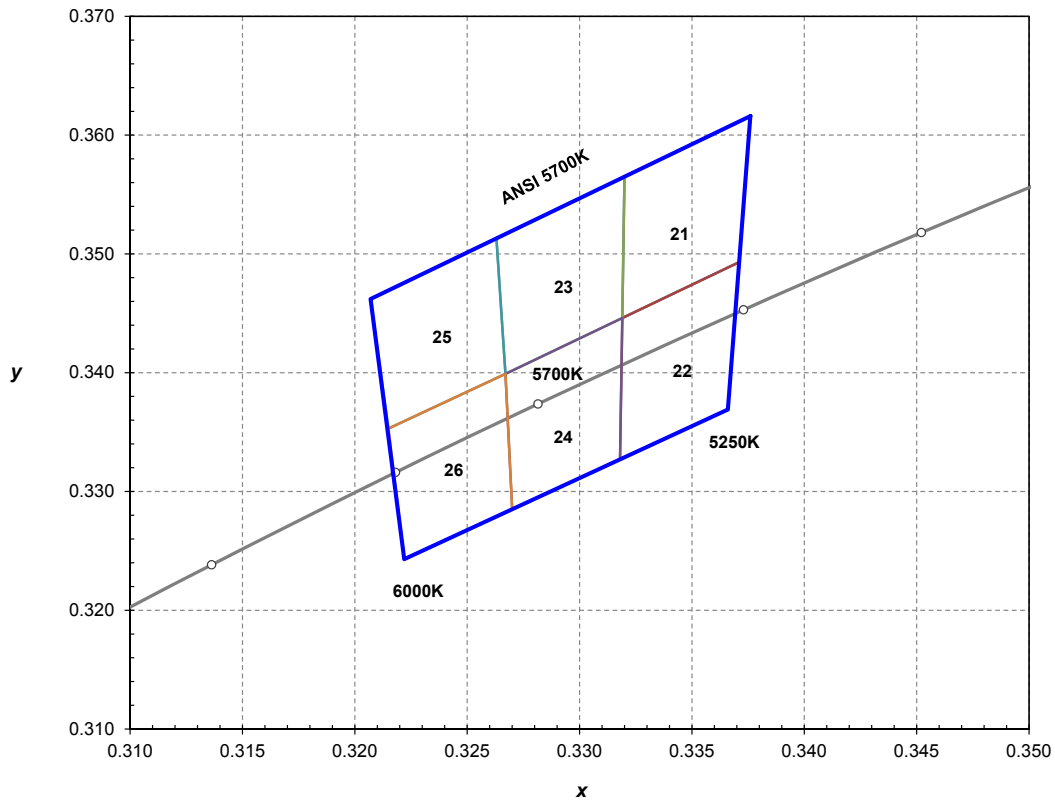

Figure 16. ANSI 5700K 1/6th color bin structure, forwards current = 30 mA, thermal pad temperature = 25°C.

LUXEON Mid-Power Emitters are tested and binned by x,y coordinates.

Table 14.

LUXEON Mid-Power ANSI 1/6 Color Bin Coordinates for MXZ8-PW57-0000 Emitter					
Bin Code	x	y	Bin Code	x	y
21	0.3319	0.3446	24	0.3270	0.3285
	0.3320	0.3565		0.3267	0.3399
	0.3376	0.3616		0.3319	0.3446
	0.3371	0.3493		0.3318	0.3327
22	0.3318	0.3327	25	0.3215	0.3353
	0.3319	0.3446		0.3207	0.3462
	0.3371	0.3493		0.3263	0.3513
	0.3366	0.3369		0.3267	0.3399
23	0.3267	0.3399	26	0.3222	0.3243
	0.3263	0.3513		0.3215	0.3353
	0.3320	0.3565		0.3267	0.3399
	0.3319	0.3446		0.3270	0.3285

**Notes for Table 14:**

I. Tested and binned at 25°C, I<sub>f</sub>=30 mA. Tester tolerance: ±0.01 in x and y coordinates.

# Color Bin Structure

## MXZ8-PW65 Color Bin Structure

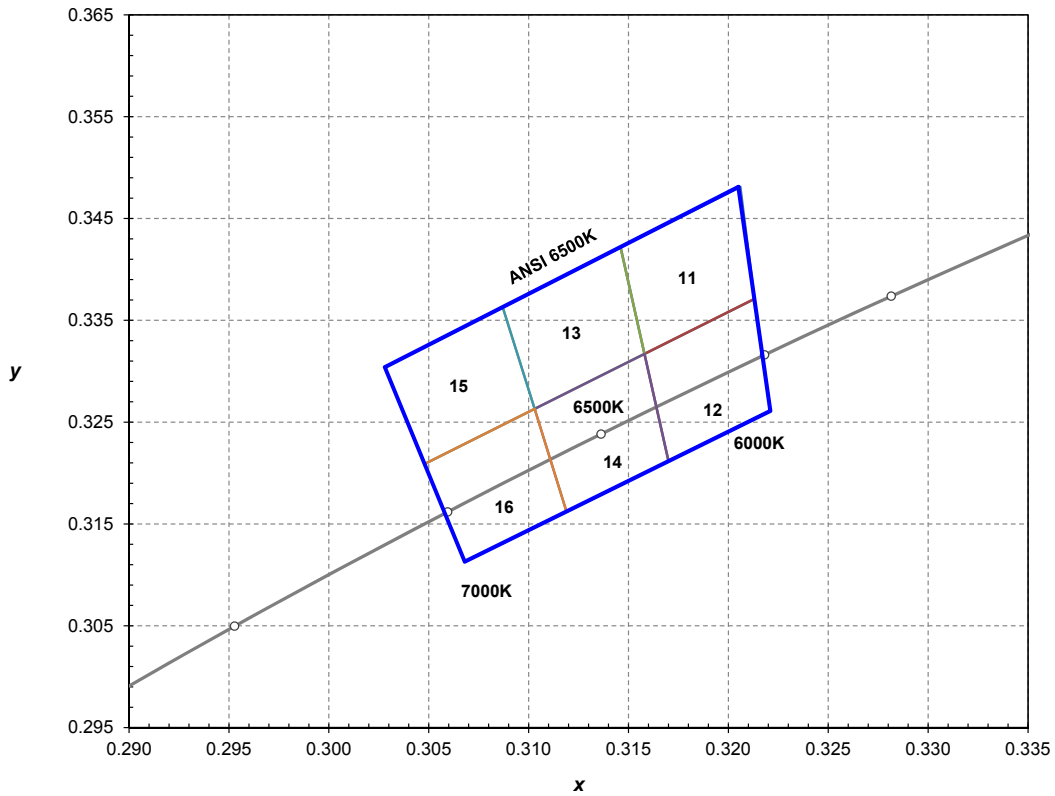

Figure 17. ANSI 6500K 1/6th color bin structure, forwards current = 30 mA, thermal pad temperature = 25°C.

LUXEON Mid-Power Emitters are tested and binned by x,y coordinates.

Table 15.

LUXEON Mid-Power ANSI 1/6 Color Bin Coordinates for MXZ8-PW65-0000 Emitter					
Bin Code	x	y	Bin Code	x	y
11	0.3158	0.3317	14	0.3119	0.3162
	0.3146	0.3422		0.3103	0.3263
	0.3206	0.3481		0.3158	0.3317
	0.3213	0.3371		0.3170	0.3212
12	0.3170	0.3212	15	0.3048	0.3209
	0.3158	0.3317		0.3028	0.3304
	0.3213	0.3371		0.3087	0.3363
	0.3221	0.3261		0.3103	0.3263
13	0.3103	0.3263	16	0.3068	0.3113
	0.3087	0.3363		0.3048	0.3209
	0.3146	0.3422		0.3103	0.3263
	0.3158	0.3317		0.3119	0.3162

**Notes for Table 15:**

I. Tested and binned at 25°C, I<sub>F</sub>=30 mA. Tester tolerance: ±0.01 in x and y coordinates.

## Who We Are

Philips Lumileds focuses on one goal: Creating the world's highest performing LEDs. The company pioneered the use of solid-state lighting in breakthrough products such as the first LED backlit TV, the first LED flash in camera phones, and the first LED daytime running lights for cars. Today we offer the most comprehensive portfolio of high quality LEDs and uncompromising service.

Philips Lumileds brings LED's qualities of energy efficiency, digital control and long life to spotlights, downlights, high bay and low bay lighting, indoor area lighting, architectural and specialty lighting as well as retrofit lamps. Our products are engineered for optimal light quality and unprecedented efficacy at the lowest overall cost. By offering LEDs in chip, packaged and module form, we deliver supply chain flexibility to the inventors of next generation illumination.

Philips Lumileds understands that solid state lighting is not just about energy efficiency. It is about elegant design. Reinventing form. Engineering new materials. Pioneering markets and simplifying the supply chain. It's about a shared vision. Learn more about our comprehensive portfolio of LEDs at [www.philipslumileds.com](http://www.philipslumileds.com).

---

Philips Lumileds Lighting Company shall not be liable for any kind of loss of data or any other damages, direct, indirect or consequential, resulting from the use of the provided information and data. Although Philips Lumileds Lighting Company has attempted to provide the most accurate information and data, the materials and services information and data are provided "as is" and Philips Lumileds Lighting Company neither warranties, nor guarantees the contents and correctness of the provided information and data. Philips Lumileds Lighting Company reserves the right to make changes without notice. You as user agree to this disclaimer and user agreement with the download or use of the provided materials, information and data.

---



©2013 Philips Lumileds Lighting Company. All rights reserved.  
LUXEON is a registered trademark of the Philips Lumileds Lighting Company in the United States and other countries.

[www.philipslumileds.com](http://www.philipslumileds.com)  
[www.philipslumileds.cn.com](http://www.philipslumileds.cn.com)