

Photosensitive Mobile Robot DIY Kit

1.Introduction:

SFT-Q03YH is a Photosensitive Mobile Robot Simulation Firefly Electronic DIY Kit. It can simulate the automatic flashing of fireflies, and according to the photosensitive sensor, it can automatically move towards light at night.It is a very interesting Mini DIY electronic product, which enables users to understand the circuit more clearly and learn welding skills.

2.Feature:

- 1>.Photosensitive automatic movement
- 2>.Breathing light flashes automatically
- 3>.Perfect simple circuit
- 4>.DIY hand soldering
- 5>.High simulation firefly

3.Parameter:

- 1>.Product Name:Photosensitive Mobile Robot Electronic DIY Kit
- 2>.Product Number:SFT-Q03YH
- 3>.Work Voltage:DC 3V
- 4>.Work Current:30mA
- 5>.Work Temperature:-40℃~85℃
- 6>.Work Humidity:5%~85%RH
- 7>.Size(Installed):60*60*35mm

4.Function:

1>.Sensitive movement:There are two photosensitive sensors on right and left (R1/R4) which simulating the antennae of fireflies. When the light reaches the antennae R1 or R4, Transistor Q1 or Q2 will turn ON and then the corresponding motor starts to vibrate, so that the firefly moves in the direction of light.

2>.Breathing light:The breathing lamp circuit is controlled by lm358 chip, which can simulate the effect of firefly's slow ON and OFF.

3>.The LED breathing light will turn OFF when moving.

5.Component Listing:

NO.	Component Name	PCB Marker	Parameter	QTY
1	LM358P	U1	DIP-8	1
2	IC Socket	U1	DIP-8	1

3	S8550 Transistor	Q1,Q2	TO-92	2
4	S9014 Transistor	Q3	TO-92	1
5	Blue LED	LED	5mm	1
6	Electrolytic Capacitor	C1	100uF	1
7	Power Switch	K	3Pin	1
8	XH2.54-2Pin Male Pin	M1,M2,DC3V	2.54mm	3
9	CR2032 Battery Socket	DC3V		1
10	Mini Vibrating Motor	M1,M2	10*3mm	2
11	Potentiometer	R8	10Kohm	1
12	Metal Film Resistor	R5,R11	100ohm	2
13	Metal Film Resistor	R2,R3	430ohm	2
14	Metal Film Resistor	R7	1.5Kohm	1
15	Metal Film Resistor	R6	3.3Kohm	1
16	Metal Film Resistor	R9,R10	10Kohm	2
17	Photoresistor	R1,R4	MG5516	2
18	PVC Support			1
19	Double Sided Adhesive Tape		20*2.5mm	1
20	Heat Shrinkable Tube		15*7mm	2
21	Red Wire		10cm	1
22	Black Wire		10cm	1
23	PCB		42*40*1.6mm	1

Note:Users can complete the installation according to the PCB silk screen and component list.

6.Schematic:

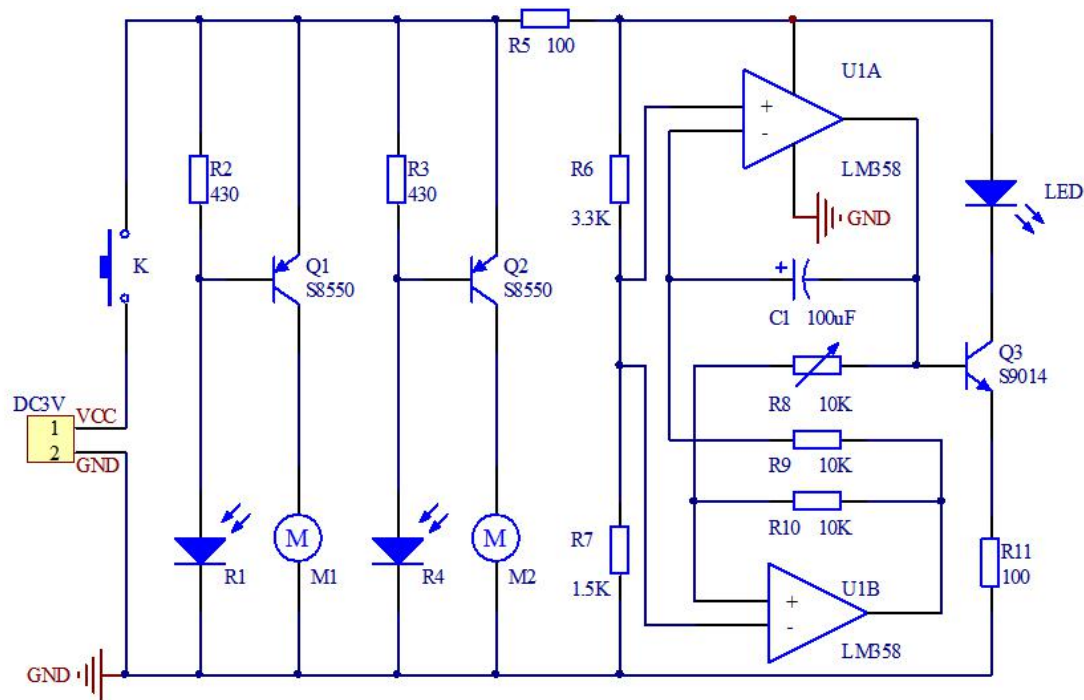

7.Application:

- 1>.Training welding skills
- 2>.Student school
- 3>.DIY production
- 4>.Project Design
- 5>.Electronic competition
- 6>.Gift giving
- 7>.Crafts collection
- 8>.Home decoration
- 9>.Souvenir collection
- 10>.Graduation design

11>.Holiday gifts

8.Installation Tips:

- 1>.User needs to prepare the welding tool at first.
- 2>.Please be patient until the installation is complete.
- 3>.The package is DIY kit.It need finish install by user.
- 4>.The soldering iron can't touch the components for a long time(1.0 second), otherwise it will damage the components.
- 5>.Pay attention to the positive and negative of the components.
- 6>.Strictly prohibit short circuit.
- 7>.User must install the LED according to the specified rules.Otherwise some LED will not light.
- 8>.Install complex components preferentially.
- 9>.Make sure all components are in right direction and right place.
- 10>.Check that all of the LED can be illuminated.
- 11>.It is strongly recommended to read the installation manual before starting installation!!!
- 12>.Please wear anti-static gloves or anti-static wristbands when installing electronic components.

9.Installation Steps(Please be patient install!!!):

- 1>.Step 1: Install 2pcs 100ohm Metal Film Resistor at R5,R11. Identify the resistor value as shown in color:Brown/Black/Black/Black/Brown.
- 2>.Step 2: Install 2pcs 430ohm Metal Film Resistor at R2,R3. Identify the resistor value as shown in color:Yellow/Orange/Black/Black/Brown.
- 3>.Step 3: Install 1pcs 1.5Kohm Metal Film Resistor at R7. Identify the resistor value as shown in color:Brown/Green/Black/Brown/Brown.
- 4>.Step 4: Install 1pcs 3.3Kohm Metal Film Resistor at R6. Identify the resistor value as shown in color:Orange/Orange/Black/Brown/Brown.
- 5>.Step 5: Install 2pcs 10Kohm Metal Film Resistor at R9,R10. Identify the resistor value as shown in color:Brown/Black/Black/Red/Brown.
- 6>.Step 6: Install 3pcs XH2.54-2P Male Pin at M1,M2,DC3V.(Users don't have to install them)
- 7>.Step 7: Install 1pcs DIP-8 IC Socket at U1.There is a groove on one end of the IC Socket and there is a groove mark on PCB where the IC Socket can place on.These two marks are corresponding to each other and are used to specify the installation direction of the IC Socket.
- 8>.Step 8: Install 2pcs TO-92 S8550 Transistor at Q1,Q2.
- 9>.Step 9: Install 1pcs TO-92 S9014 Transistor at Q3.
- 10>.Step 10: Install 1pcs 5mm Blue LED at LED.The longer pin is inserted into mark ' + ' (positive pole).
- 11>.Step 11: Install 1pcs 100uF Electrolytic Capacitor at C1.Pay attention to distinguish between positive and negative.The Longer pin is positive pole which marked ' + '.
- 12>.Step 12: Install 1pcs Power Switch at K.
- 13>.Step 13: Install 1pcs 10Kohm Potentiometer at R8.
- 14>.Step 14: Install 1pcs DIP-8 IC LM358P at U1.There is a groove on one end of the IC and there is a groove mark on PCB where the IC can place on.These two marks are corresponding to each other and are used to specify the installation direction of the IC.
- 15>.Step 15: Install 2pcs MG5516 Photoresistor at R1,R4. Note:The distance between the sensor and PCB is about 10mm.

16>.Step 16: Put 2pcs Heat Shrinkable Tube on MG5516 Photoresistor.

17>.Step 17: Install 2pcs Mini Vibrating Motor at M1,M2(Connect to XH2.54-2P Male Pin). Note that the wires cannot be kept too long(5mm is OK).

18>.Step 18: Connect red and black wire to DC XH2.54-2P Male Pin. Note:Red wire connect to ' + ' and Black wire connect to ' - '.

19>.Step 19: Bend the three pins of PVC bracket.

20>.Step 20: Paste PVC bracket onto PCB with a Double Sided Adhesive Tape.

21>.Step 21: Paste 2pcs motor on PVC bracket.

22>.Step 22: Connect Red wire to positive pole from battery socket and Black wire to another pin.Pay attention to distinguish between positive and negative.Note that the wires cannot be kept too long(3cm is OK).

23>.Step 23: Paste CR2032 Battery Socket onto PVC bracket with a Double Sided Adhesive Tape.

24>.Step 24: Install CR2032 battery(Not included!) and enjoy the effect.

10.Install shown steps:

Step 1: Install 2pcs 100ohm Metal Film Resistor at R5,R11. Identify the resistor value as shown in color:Brown/Black/Black/Black/Brown.

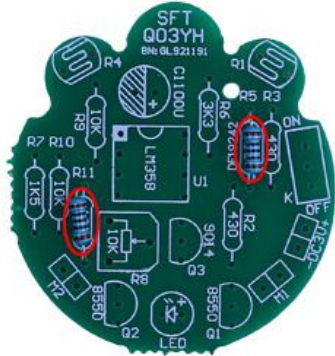

Step 2: Install 2pcs 430ohm Metal Film Resistor at R2,R3. Identify the resistor value as shown in color:Yellow/Orange/Black/Black/Brown.

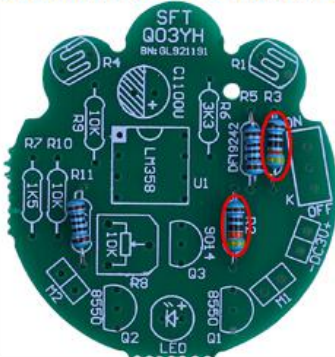

Step 3: Install 1pcs 1.5Kohm Metal Film Resistor at R7. Identify the resistor value as shown in color:Brown/Green/Black/Brown/Brown.

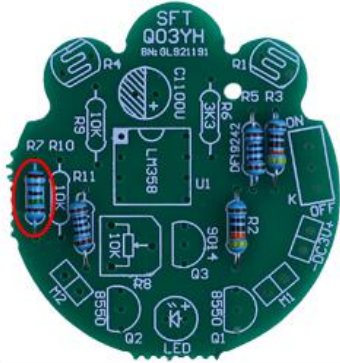

Step 4: Install 1pcs 3.3Kohm Metal Film Resistor at R6. Identify the resistor value as shown in color:Orange/Orange/Black/Brown/Brown.

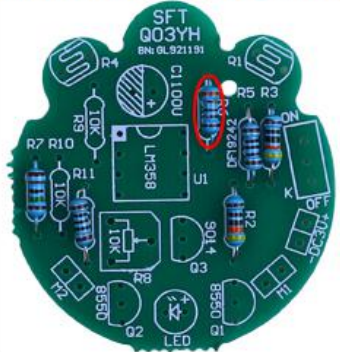

Step 5: Install 2pcs 10Kohm Metal Film Resistor at R9,R10. Identify the resistor value as shown in color:Brown/Black/Black/Red/Brown.

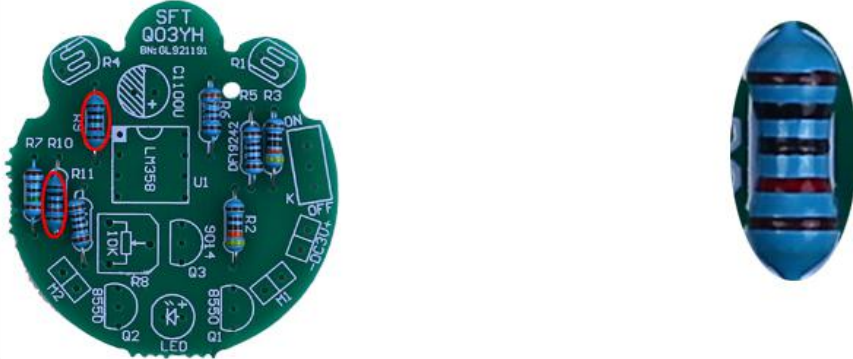

Step 6: Install 3pcs XH2.54-2P Male Pin at M1,M2,DC3V.(Users don't have to install them)

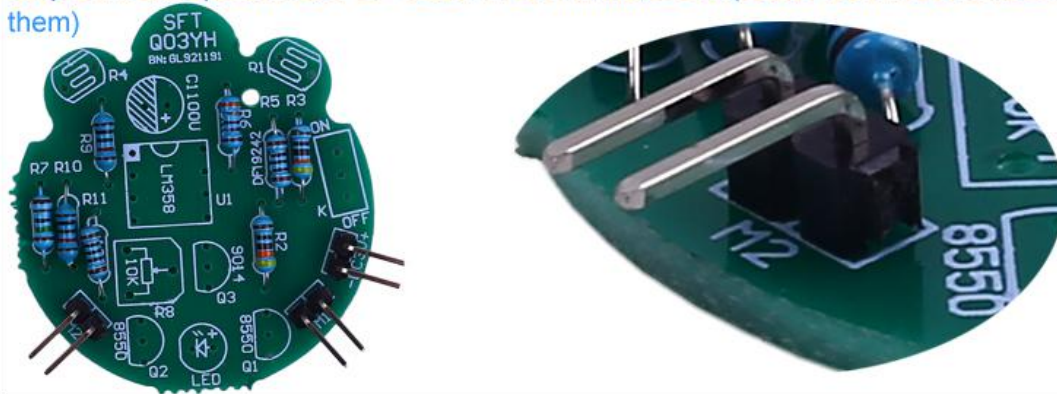

Step 7: Install 1pcs DIP-8 IC Socket at U1. There is a groove on one end of the IC Socket and there is a groove mark on PCB where the IC Socket can place on. These two marks are corresponding to each other and are used to specify the installation direction of the IC Socket.

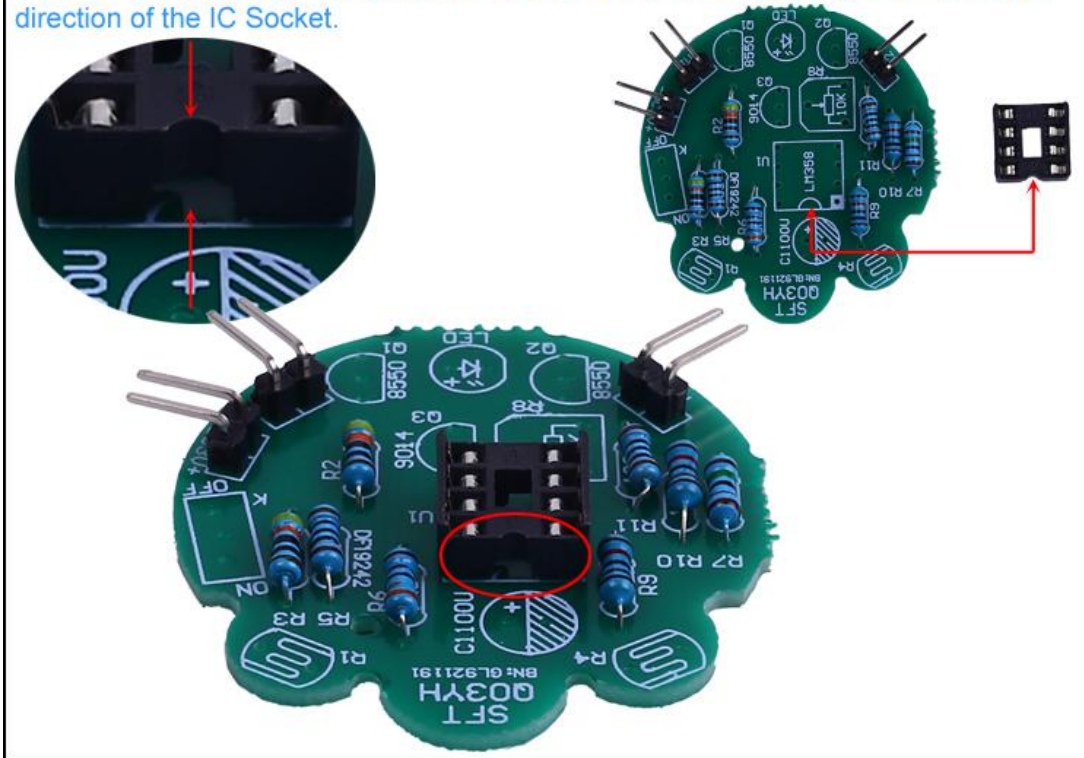

Step 8: Install 2pcs TO-92 S8550 Transistor at Q1,Q2.

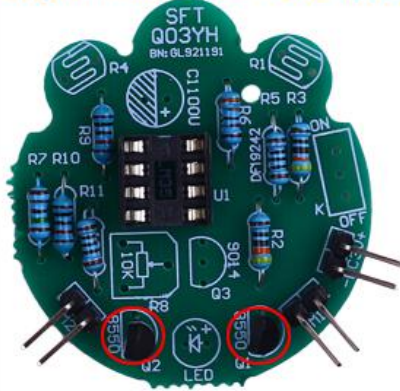

Step 9: Install 1pcs TO-92 S9014 Transistor at Q3.

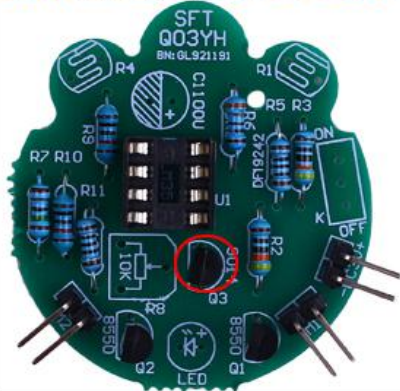

Step 10: Install 1pcs 5mm Blue LED at LED. The longer pin is inserted into mark ' + ' (positive pole).

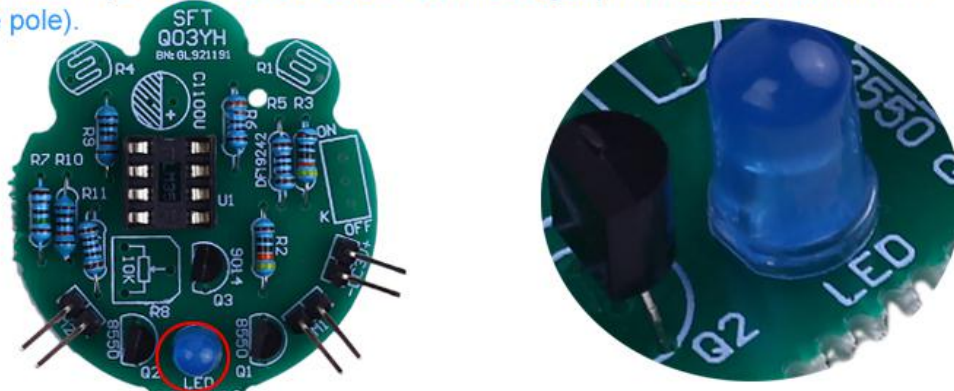

Step 11: Install 1pcs 100uF Electrolytic Capacitor at C1. Pay attention to distinguish between positive and negative. The Longer pin is positive pole which marked ' + '.

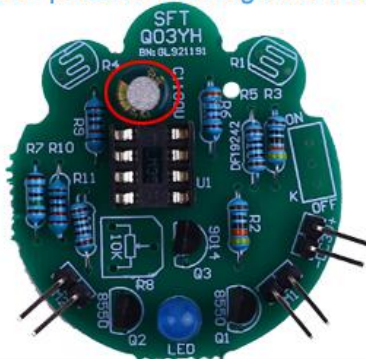

Step 12: Install 1pcs Power Switch at K.

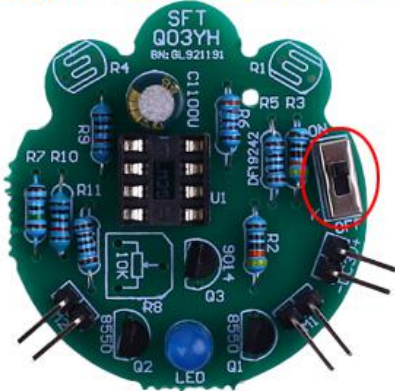

Step 13: Install 1pcs 10Kohm Potentiometer at R8.

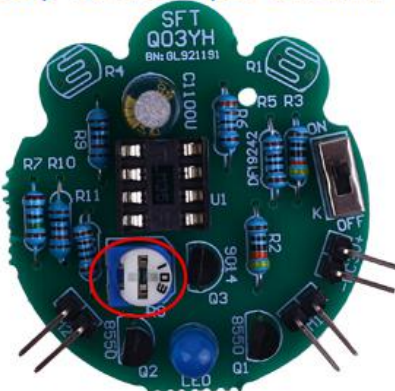

Step 14: Install 1pcs DIP-8 IC LM358P at U1. There is a groove on one end of the IC and there is a groove mark on PCB where the IC can place on. These two marks are corresponding to each other and are used to specify the installation direction of the IC.

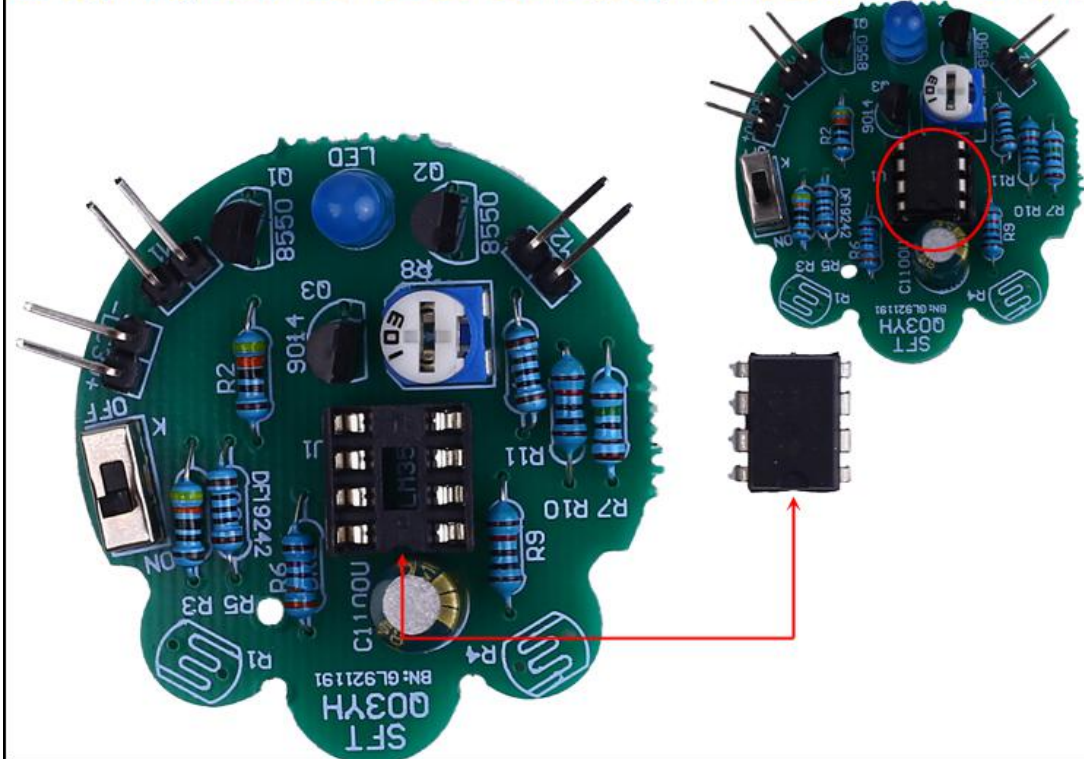

Step 15: Install 2pcs MG5516 Photoresistor at R1,R4. Note:The distance between the sensor and PCB is about 10mm.

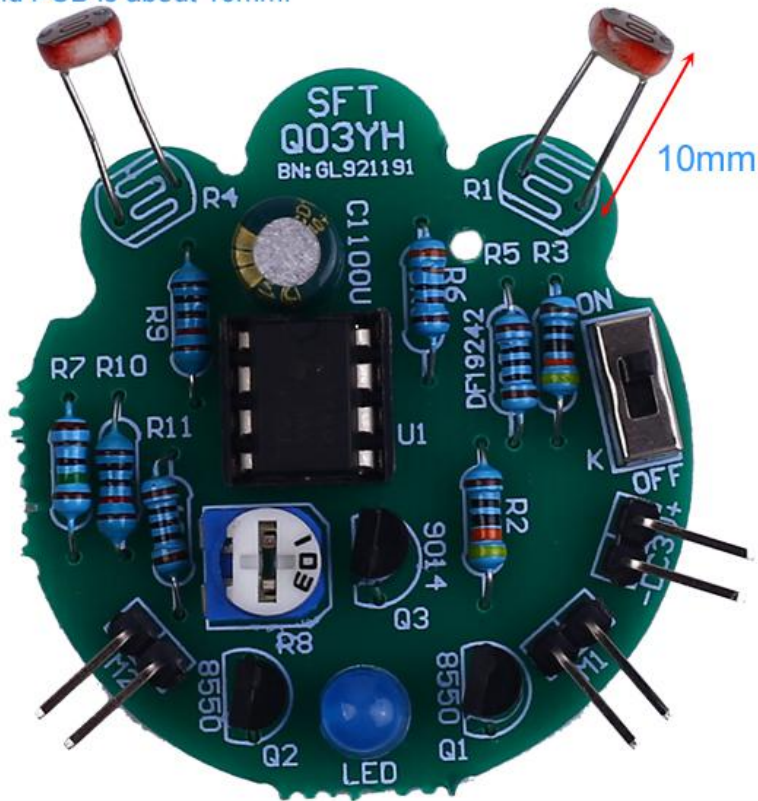

Step 16: Put 2pcs Heat Shrinkable Tube on MG5516 Photoresistor.

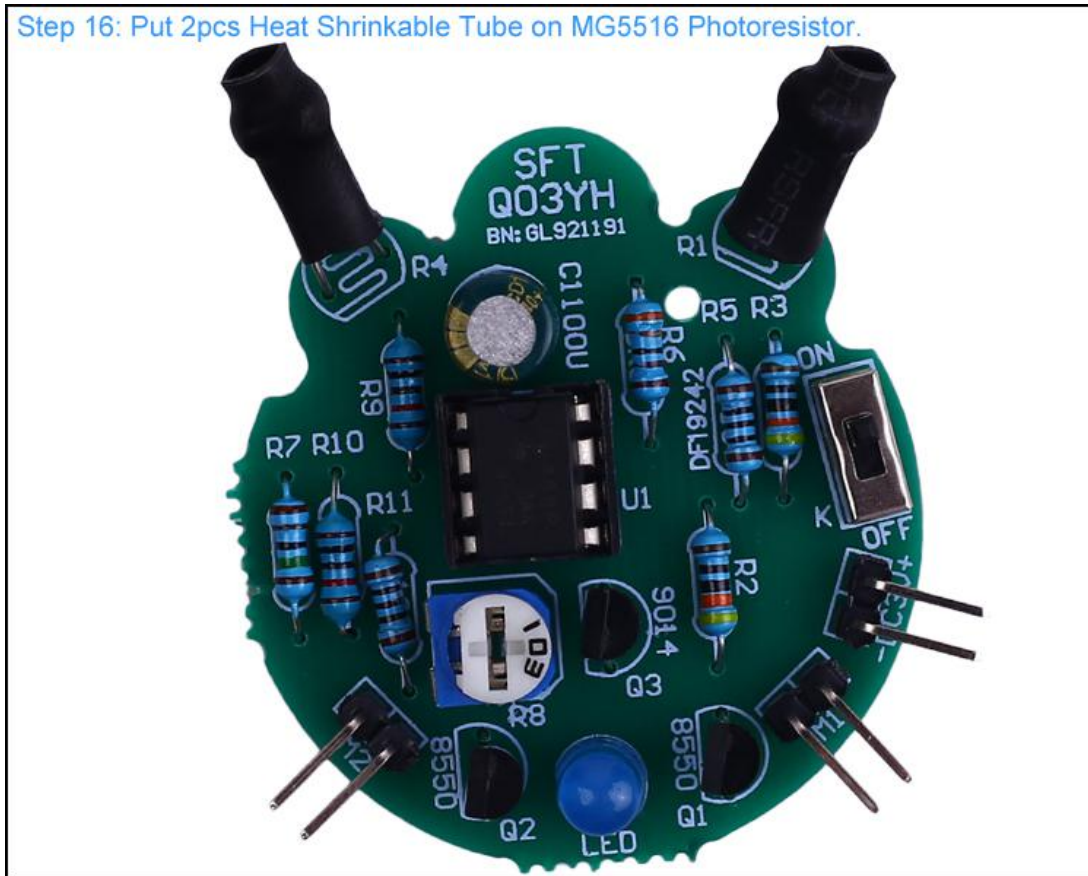

Step 17: Install 2pcs Mini Vibrating Motor at M1,M2(Connect to XH2.54-2P Male Pin).
Note that the wires cannot be kept too long(5mm is OK).

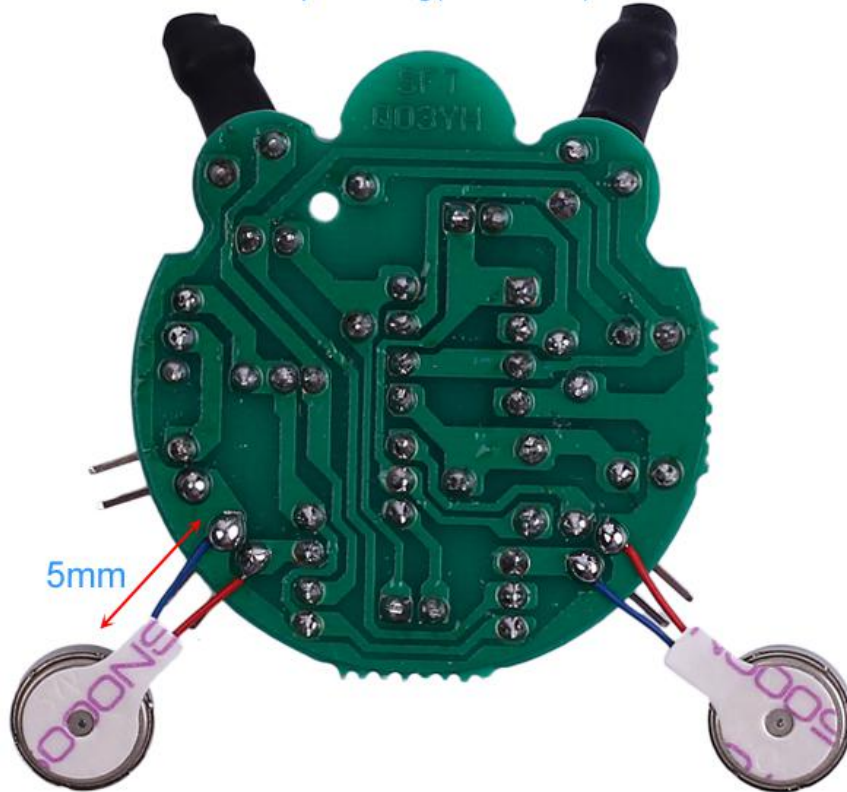

Step 18: Connect red and black wire to DC XH2.54-2P Male Pin.
Note: Red wire connect to ' + ' and Black wire connect to ' - '.

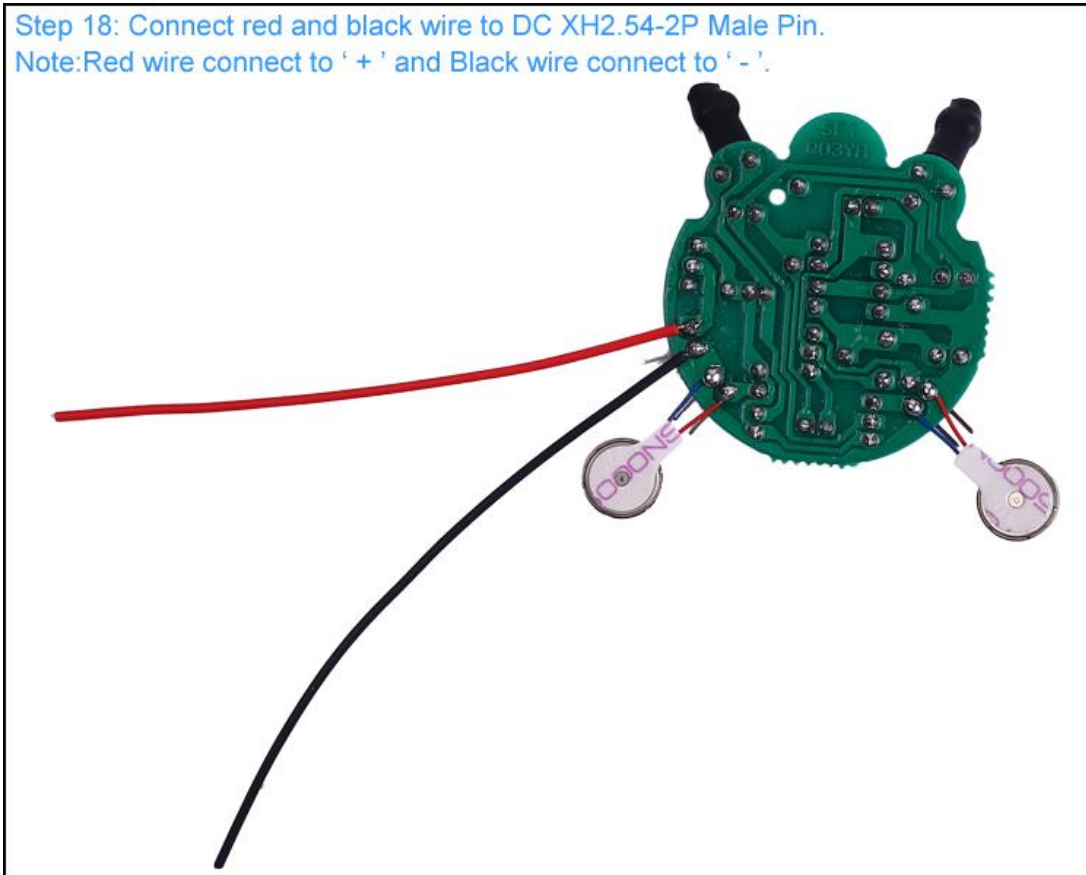

Step 19: Bend the three pins of PVC bracket.

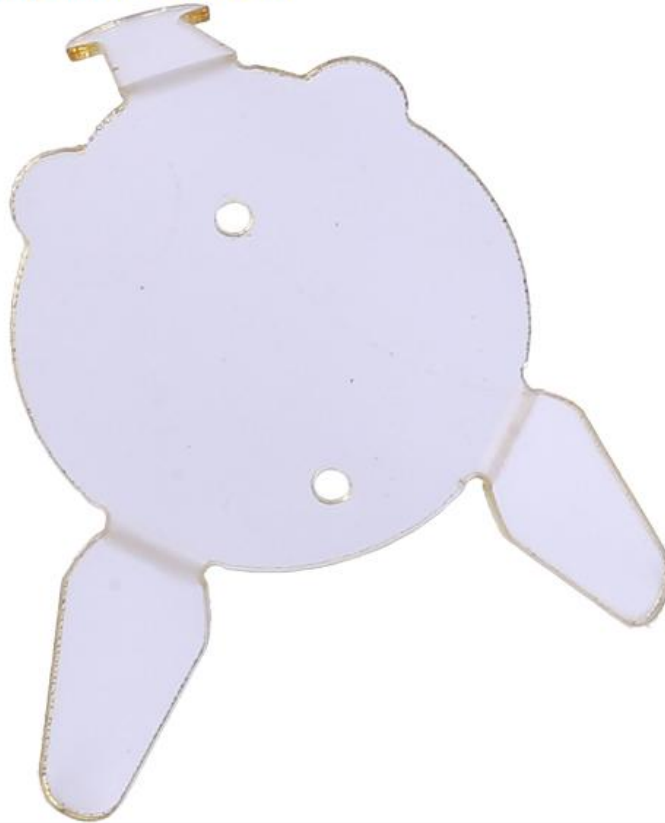

Step 20: Paste PVC bracket onto PCB with a Double Sided Adhesive Tape.

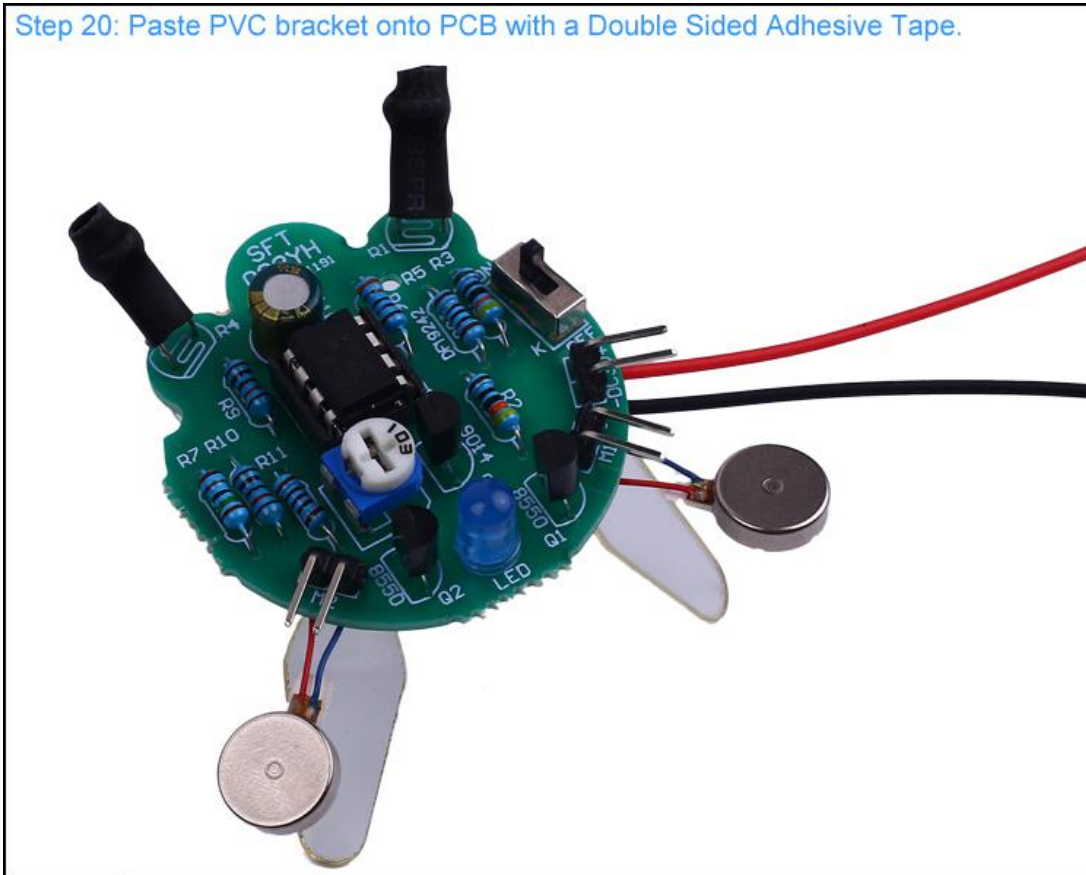

Step 21: Paste 2pcs motor on PVC bracket.

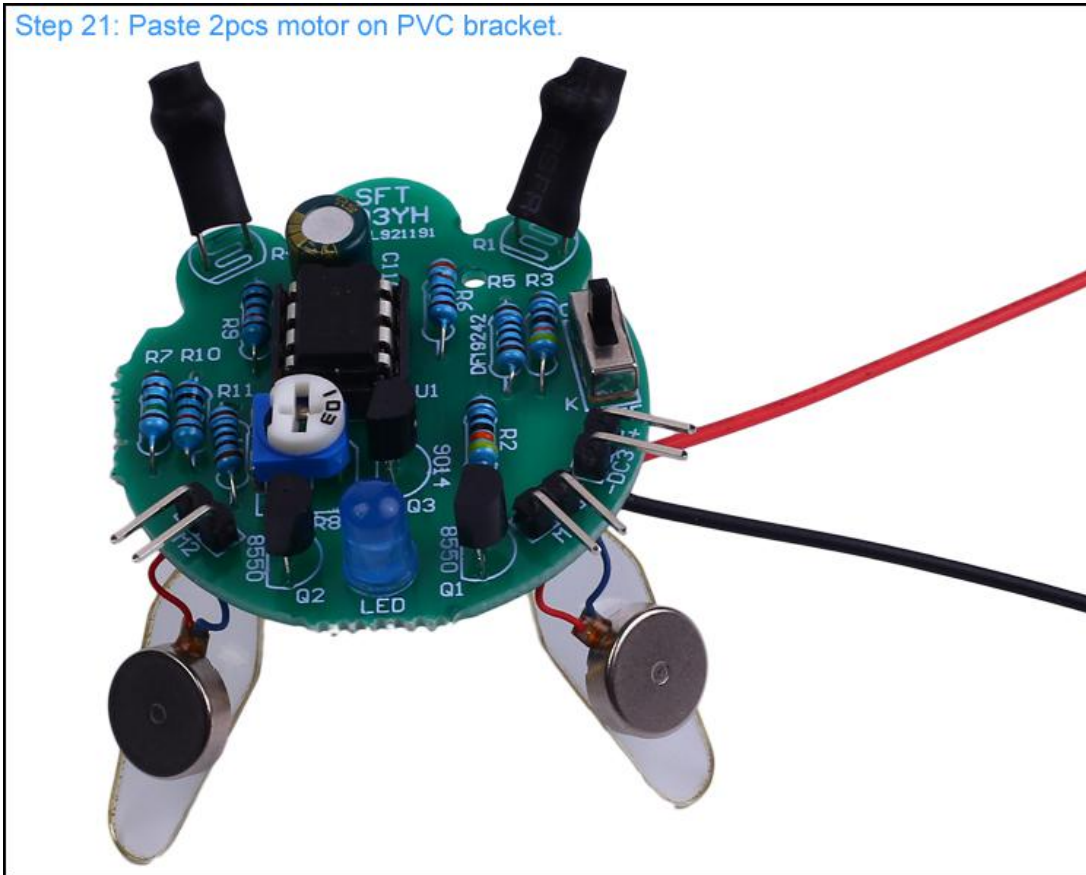

Step 22: Connect Red wire to positive pole from battery socket and Black wire to another pin. Pay attention to distinguish between positive and negative. Note that the wires cannot be kept too long (3cm is OK).

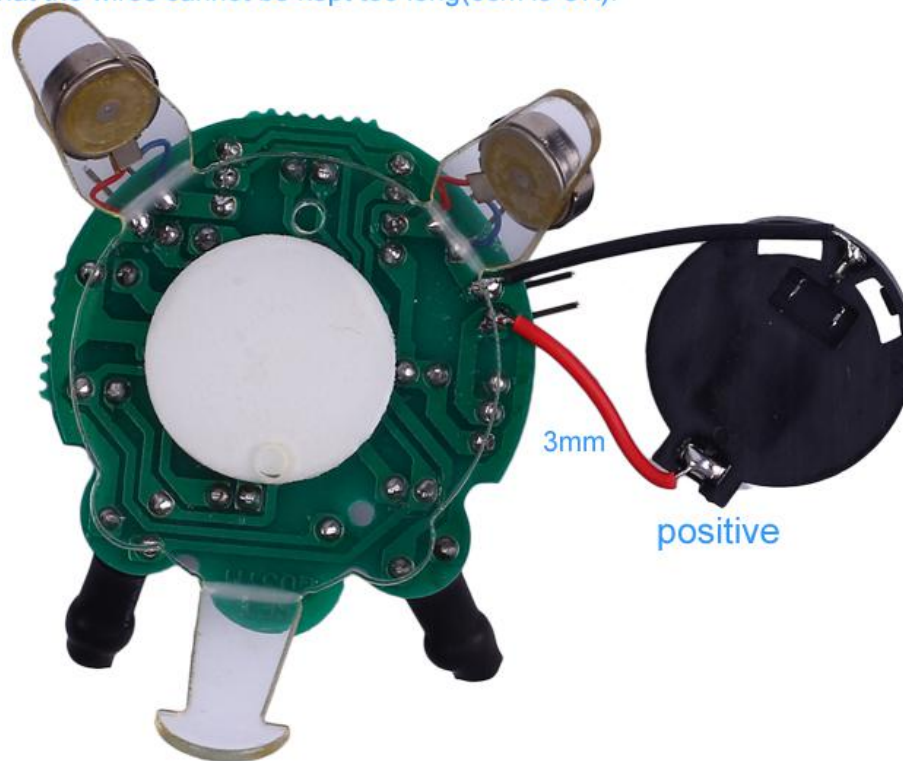

Step 23: Paste CR2032 Battery Socket onto PVC bracket with a Double Sided Adhesive Tape.



Step 24: Install CR2032 battery(Not included!) and enjoy the effect.

