

GENERAL DESCRIPTION

The NE5532 are high-performance operational amplifiers combining excellent dc and ac characteristics. They feature very low noise, high output-drive capability, high unity-gain and maximum-output-swing bandwidths, low distortion, high slew rate, input-protection diodes, and output short-circuit protection. These operational amplifiers are compensated internally for unity-gain operation. These devices have specified maximum limits for equivalent input noise voltage.

FEATURES

- ◆ Supply voltage: $\pm 3V \sim \pm 22V$.
- ◆ Large DC voltage gain: 100 dB,
- ◆ Unity-Gain bandwidth: 10 MHz Type.
- ◆ High Slew rate: $9V/\mu s$ Typ.
- ◆ Package outline: DIP8, SOIC8

APPLICATIONS

- Audio AC-3 decoded system.
- Audio amplifier

Functional Diagram

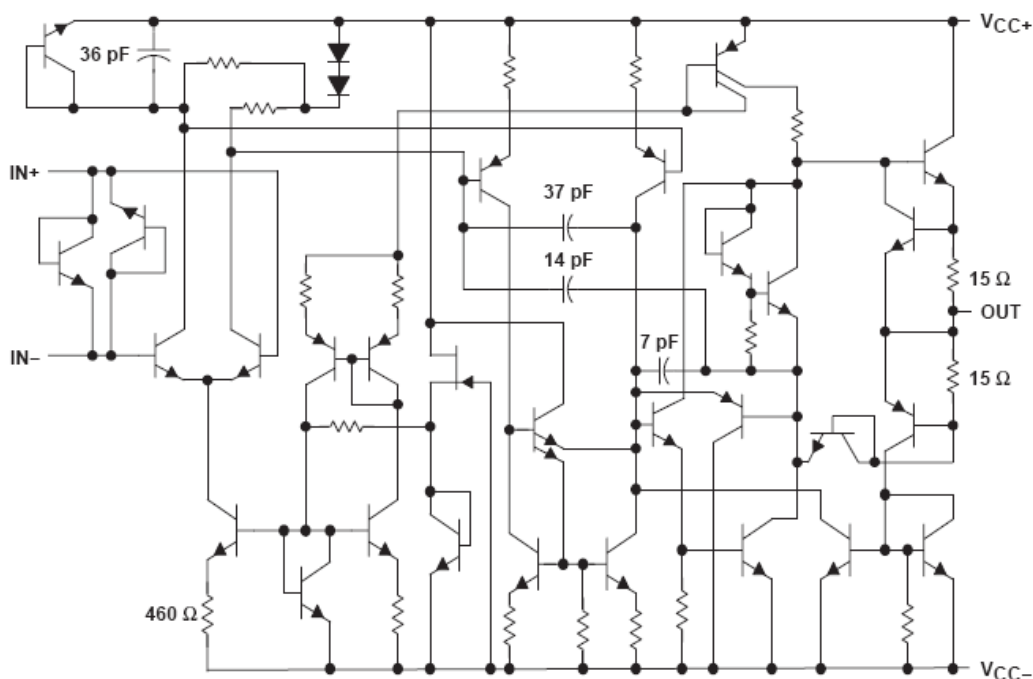

Pin Description

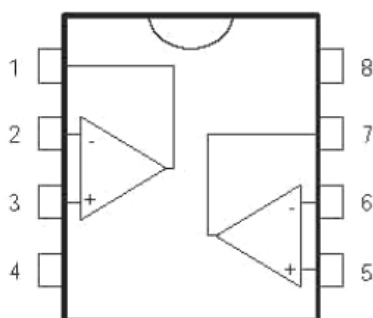

Symbol	Pin NO.	Description
OUT1	1	Output 1
IN1-	2	Inverting input1
IN1+	3	Non- Inverting input1
V-	4	VEE
IN2+	5	Non- Inverting input2
IN2-	6	Inverting input2
OUT2	7	Output 2
V+	8	VCC

Absolute maximum ratings over operating free-air temperature range.

Parameter	Symbol	Value	Unit
Supply Voltage	V_{CC}	± 22	V
Differential Input Voltage	$V_{(DIFF)}$	± 30	V
Input Voltage	V_I	± 15	V
Duration of output short circuit to ground,one amplflfer at a time		Unlimited	
Short temperature range	T_{STG}	-65to150	°C

Recommended operating conditions

Parameter	Symbol	MIN	MAX	UNIT
Supply voltage	VCC+	5	15	V
	VCC-	-5	-15	
Operating free-air temperature. T_A	NE5532	0	70	°C

**Electrical characteristics at specified free-air temperature, $V_{CC} = 15V$
(unless otherwise noted)**

PARAMETER		TEST CONDITIONS*		NE5532			UNIT
				MIN	TYP	MAX	
Vio Input Offset Voltage		VO=0	25°C		0.5	4	mV
			Full Range			5	
V01/V02 Crosstalk attenuation	Open	PS=100 Ω F=1KHZ	25°C		85		
	AVD=100				100		
Io Input Offset Current		VO=0	25°C		5	150	nA
			Full Range			200	
rj		Input resistance	25°C	0	5		M Ω
IIB Input Bias Current		VO=0	25°C		140	500	nA
			Full Range			1000	
VICR Common-Mode Input Voltage range			25°C	± 12	± 14		V
VOM Maximum output voltage swing		RL=10k Ω	25°C	± 12	± 14		V
		RL=2k Ω	25°C	± 10	± 13		
		RL ≥ 2k Ω	Full Range	± 10			
AVD Large-Signal Differential Voltage Amolification		VO= ± 10 RL ≥ 2k Ω	25°C	25	100		V/mV
			Full Range	15			
CMRR Common-Mode Rejection Ratio		Vcc=5V to MAX. VIC=VICRMIN	25°C	65	100		dB
Ksvs Supply Voltage Sensltlvty Ratlo($\Delta V_{ID}/\Delta V_{CC}$)			25°C		30	150	uV/V
V01/V02 Crosstalk Attenuation		f=1 KHZ to 20KHZ	25°C		120		dB
Icc Supply Current (Both Amplifiers)		Vo=O.No Load	25°C		2.5	5.6	mA
			TA(min)		3.0	6.6	
			TA(max)		2.0	5.0	

*All characterlstics are measured under open-loop conditions with zero common-mode input coltage unless Otherwise specified.Full range is 0°C to 70°C.TA(min)=0°C.TA(max)=70°C.

Typical Performance Characteristics

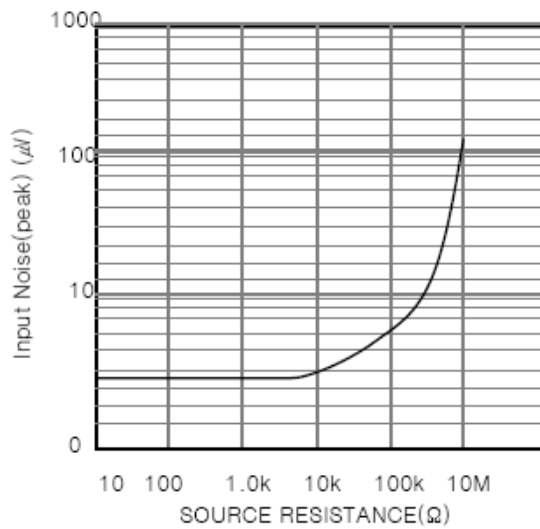

Figure 1. Burst Noise vs Source Resistance

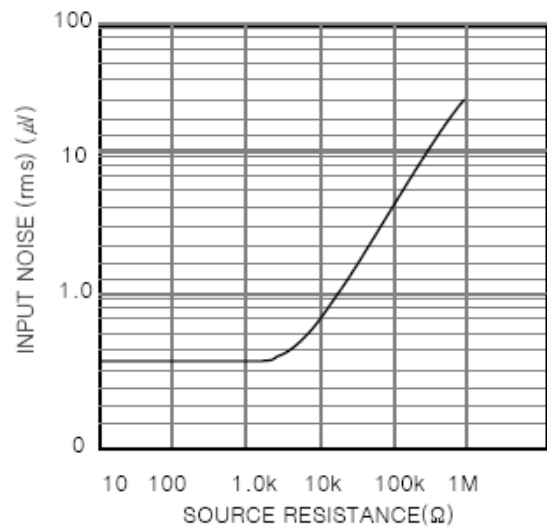

Figure 2. RMS Noise vs Source Resistance

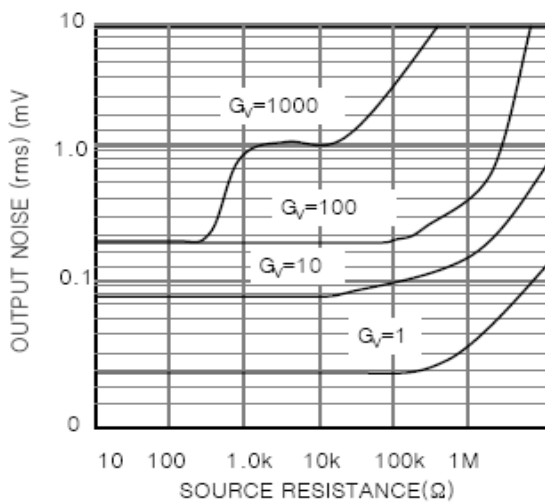

Figure 3. Output Noise vs Source Resistance

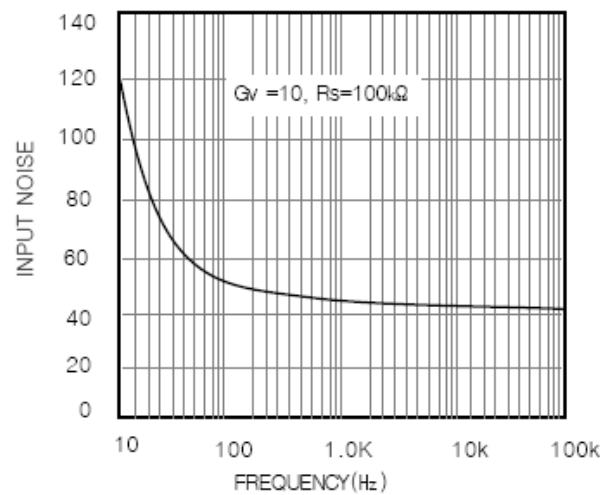

Figure 4. Spectral Noise Density

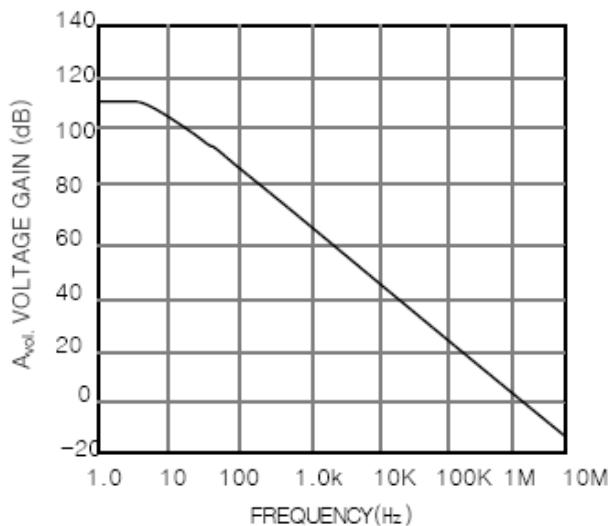

Figure 5. Open Loop Frequency Response

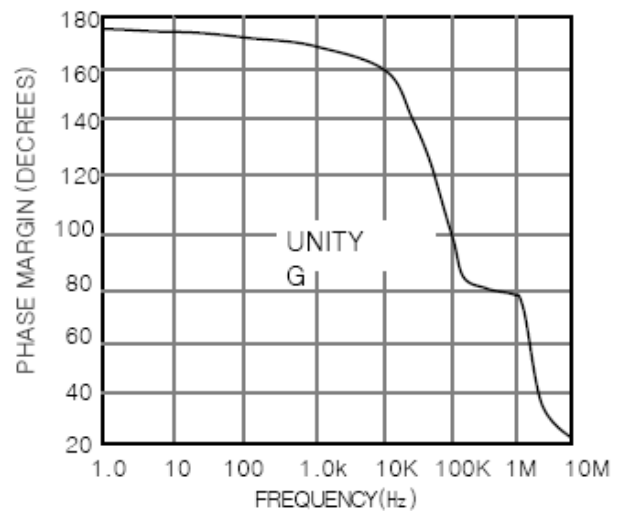

Figure 6. Phase Margin vs Frequency

NE5532

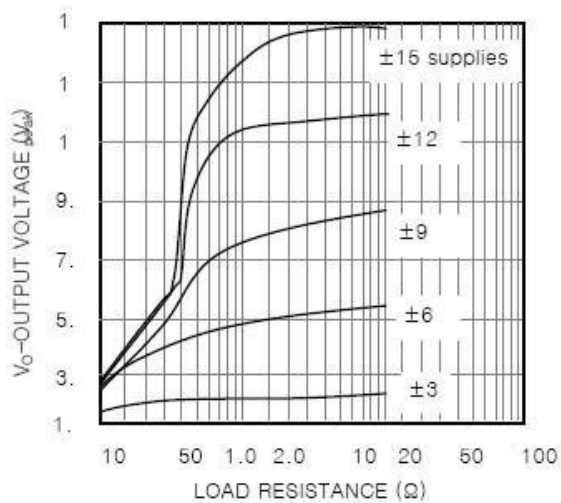

Figure 7. Positive Output Voltage Swing vs Load Resistance

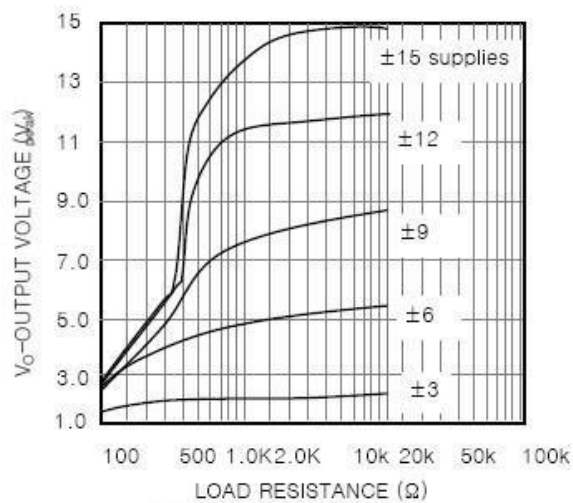

Figure 8. Negative Output Voltage Swing vs Load Resistance

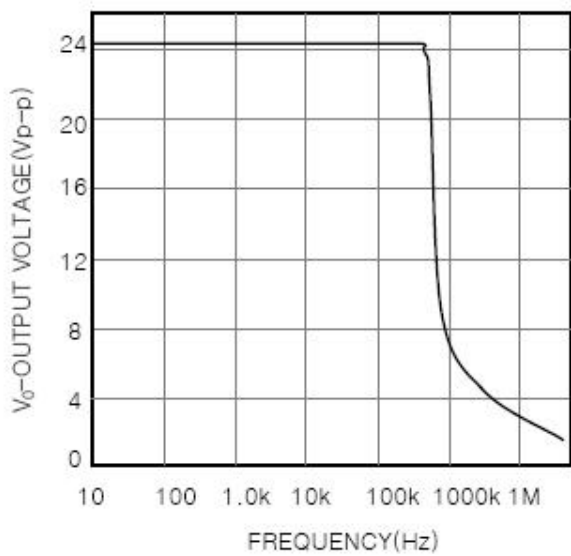
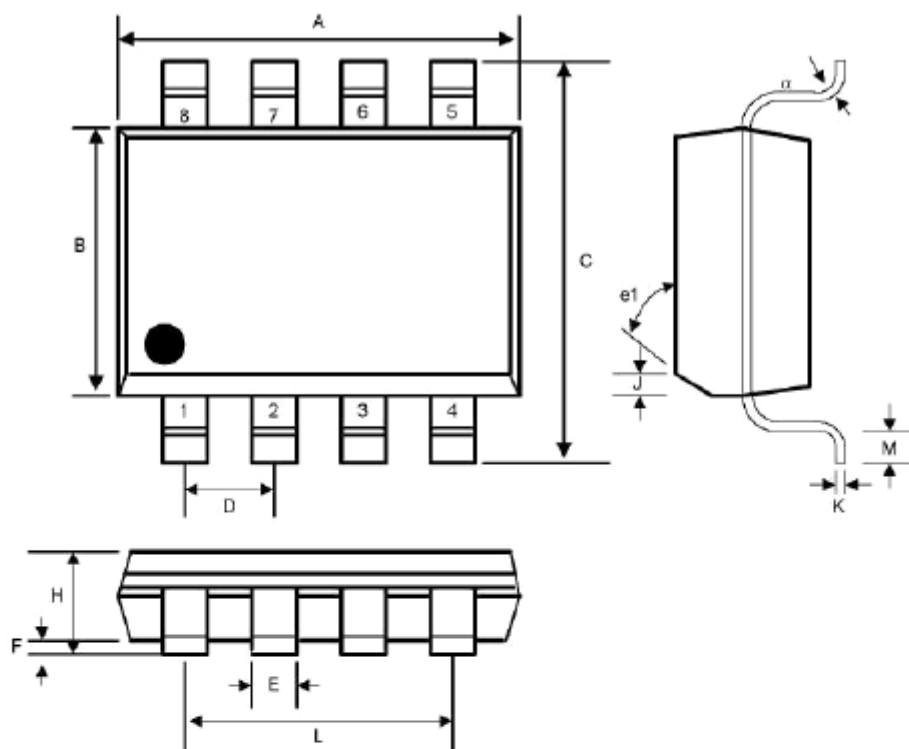
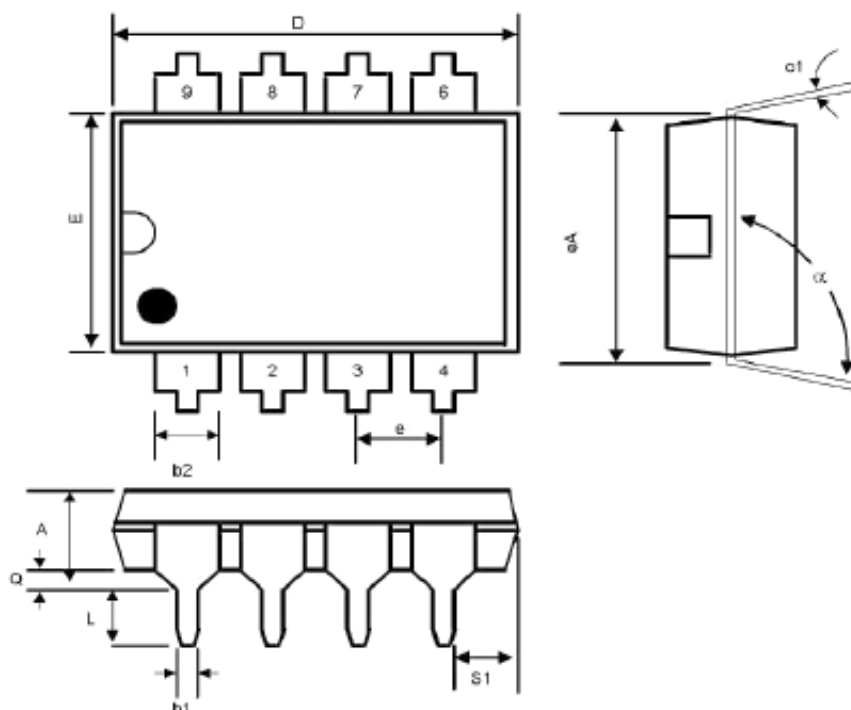

Figure 9. Power Bandwidth



SYMBOL	INCHES		MILLIMETERS		NOTES
	MIN	MAX	MIN	MAX	
A	0.188	0.197	4.80	5.00	-
B	0.149	0.158	3.80	4.00	-
C	0.228	0.244	5.80	6.20	-
D	0.050	BSC	1.27	BSC	-
E	0.013	0.020	0.33	0.51	-
F	0.004	0.010	0.10	0.25	-
H	0.053	0.069	1.35	1.75	-
J	0.011	0.019	0.28	0.48	-
K	0.007	0.010	0.19	0.25	-
M	0.016	0.050	0.40	1.27	-
L	0.150	REF	3.81	REF	-
e1	45°		45°		-
a	0°	8°	0°	8°	-

DIP8 PACKAGE OUTLINE DIMENSIONS



SYMBOL	INCHES		MILLIMETERS		NOTES
	MIN	MAX	MIN	MAX	
A	-	0.200	-	5.08	-
b1	0.014	0.023	0.36	0.58	-
b2	0.045	0.065	1.14	1.65	-
c1	0.008	0.015	0.20	0.38	-
D	0.355	0.400	9.02	10.16	-
E	0.220	0.310	5.59	7.87	-
e	0.100 BSC		2.54 BSC		-
eA	0.300 BSC		7.62 BSC		-
L	0.125	0.200	3.18	5.08	-
Q	0.015	0.060	0.38	1.52	-
s1	0.005	-	0.13	-	-
α	90 ⁰	105 ⁰	90 ⁰	105 ⁰	-